

INSTALLATION INSTRUCTIONS

Horizon® Headwall System (Chaseless) From Hill-Rom

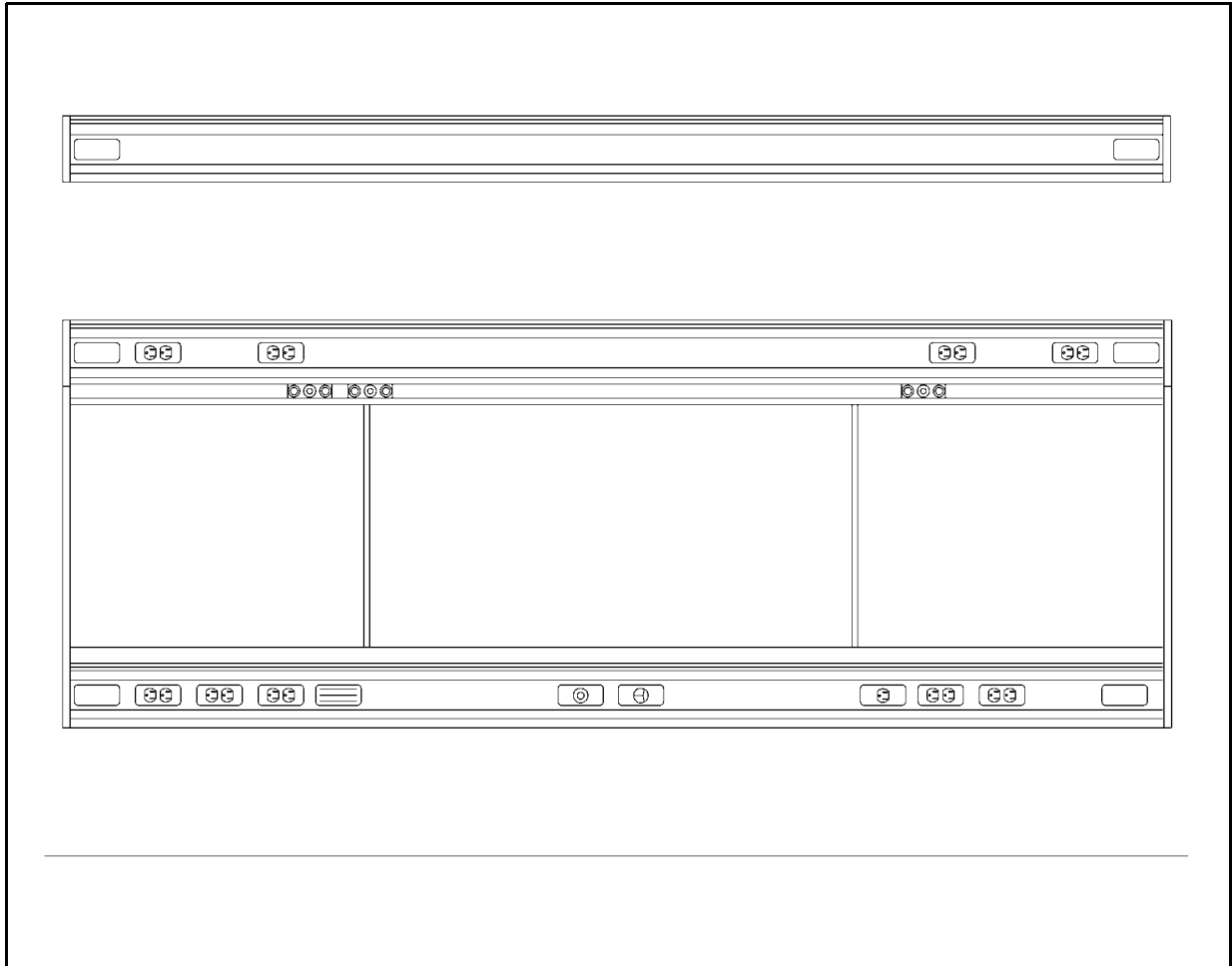

Product No. P1000

For Parts or Technical Assistance

Technical Support: (800) 445-3720

Customer Service: (800) 445-3730

Canada: (800) 267-2337

International: Contact your distributor.

www.hill-rom.com

is564ra

Horizon® Headwall System (Chaseless) Installation Instructions

Revision Letter	Pages Affected	Date
Original Issue		December, 2001
A	All	December, 2003

is564ra

© 2003 by Hill-Rom Services, Inc. ALL RIGHTS RESERVED.

No part of this text shall be reproduced or transmitted in any form or by any means, electronic or mechanical, including photocopying, recording, or by any information or retrieval system without written permission from Hill-Rom Services, Inc. (Hill-Rom).

The information in this manual is confidential and may not be disclosed to third parties without the prior written consent of Hill-Rom.

Second Edition

Printed in the USA

E-Z Ancor® is a registered trademark of Illinois Tool Works, Inc.

Hill-Rom® is a registered trademark of Hill-Rom Services, Inc.

Horizon® is a registered trademark of Hill-Rom Services, Inc.

National Electrical Code® is a registered trademark of National Fire Protection Association, Inc.

NEC® is a registered trademark of National Fire Protection Association, Inc.

The information contained in this document is subject to change without notice. Hill-Rom makes no commitment to update or keep current, the information contained in this document.

The only product warranty intended by Hill-Rom is the express, written warranty accompanying the bill of sale to the original purchaser. Hill-Rom makes no other warranty, express or implied, and in particular, makes no warranty of merchantability or fitness for a particular purpose.

Additional copies of this document can be obtained from Hill-Rom.

Table of Contents

Introduction.....	1
Code Compliance	3
Order of Installation	4
Fastener Identification	5
Determining the Wall/Construction Type.....	6
Installing the Rough-in Box(es) (P1034)	7
Making the Electrical and Gas Services Drops	10
Installing the Medical Gas Manifold	11
Installing the Raceway Hanger Brackets	13
Installing the Horizontal Raceways	16
Installing Additional Horizontal Raceway Sections.....	19
Installing the Hose Panels.....	20
Connecting the Medical Gas Outlets	23

NOTES:

Subject: Horizon® Headwall System (Chaseless) Installation Instructions

Introduction

This installation instruction sheet describes how to install the Horizon® Headwall System (see figure 1 on page 1). Prior to installing the headwall system, carefully read **all** of the installation instructions for the components you are installing.

Figure 1. Horizon® Headwall System

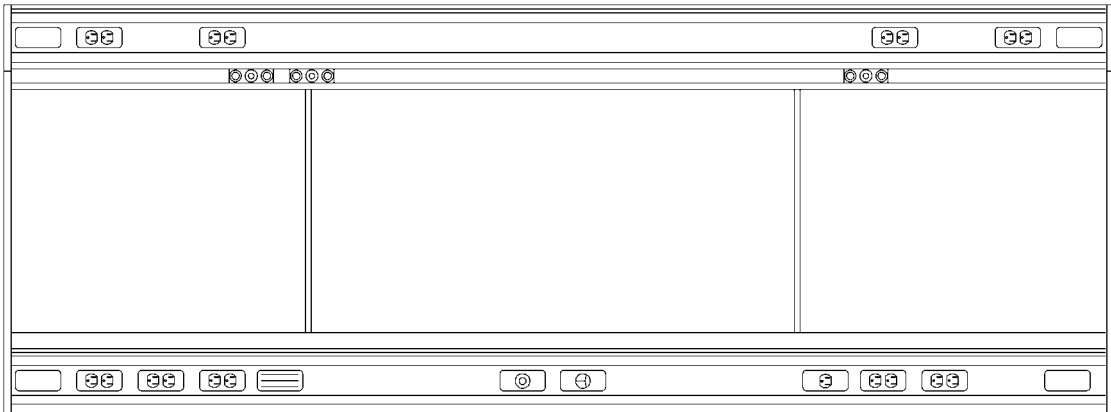
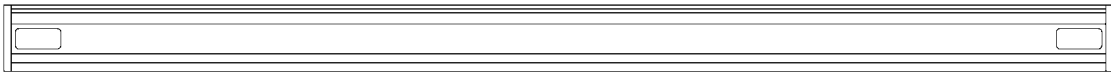

i564_001

Prior to installing the headwall system's components, the facility's medical gases and vacuum lines should have been installed in the general location.

Tools required:	Standard drill or power screwdriver	Phillips head screwdriver
	¼" diameter drill bit	15/16" diameter drill bit
	Ratchet wrench	Assorted socket wrenches
	Socket extensions	Tape measure
	Level	Chalk line
	Safety glasses	Broom
	Dustpan	Heat shield blanket(s)
Parts required:	(12) 21045	Toggle bolt (3/8"-16 x 3", slotted, round)
	(12) 21046	Toggle wing (3/8"-16)
	(18) 53143-01	Screw, #12, self-drilling, hex head
	(12) 29325	Stud guide
	(4) 52077-39	Bottom anchor—primed
	(4) 57185	E-Z Ancor [®] ¹ screw anchor
	(4) 55138	Screw, #8-18, type AB, pan head
	(8) 15250	Locknut, washer base
	(11) 15384	Toggle wing
	(11) 50167	Screw (#10-24 x 3", round head)
	(3) P1034	Wall box

Related Documents: [Horizon® Headwall System Service Manual \(man043\)](#)

1. E-Z Ancor[®] is a registered trademark of Illinois Tool Works, Inc.

Code Compliance

The **installing contractor** should follow, in all respects, the requirements of applicable state and local codes, and the following:

- National Fire Protection Association (NFPA) 99, *Standards for Health Care Facilities*
- NFPA 70, *National Electrical Code*^{®1} (NEC^{®2})
- Canadian Standards Association (CSA) Z305.1, *Non-Flammable Medical Gas Piping Systems*
- CSA C22.1, *Canadian Electrical Code—Safety Standard for Electrical Installations*
- CSA Z318.5, *Commissioning of Electrical Gas Equipment and Standards in Health Care Facilities*
- CSA Z318.6, *Commissioning of Medical Gas Systems in Health Care Facilities*
- CSA Z318.7, *Commissioning of Communication Systems in Health Care Facilities*

1. National Electrical Code[®] is a registered trademark of National Fire Protection Association, Inc.

2. NEC[®] is a registered trademark of National Fire Protection Association, Inc.

Order of Installation

The numbered steps below correspond with the order of installation for the listed components. To identify the listed components, refer to figure 2 on page 4.

Figure 2. Component Identification

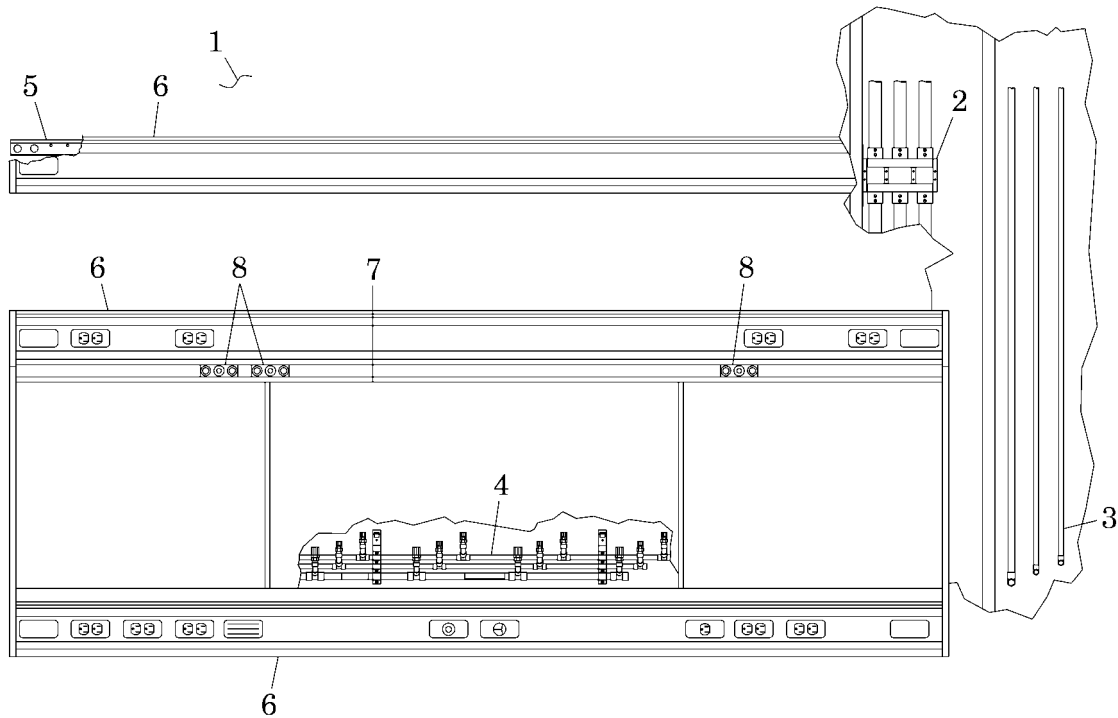

i564_002

1. Determine the wall/construction type.
2. Install the rough-in boxes.
3. Make the electrical and gas services drops.
4. Install the medical gas manifold.
5. Install the raceway hanger brackets.
6. Install the horizontal raceways.
7. Install the hose panels.
8. Connect the medical gas outlets.

Fastener Identification

For correct fastener identification, the following fasteners in the installation instructions are referred to by callout letter (see figure 3 on page 5):

Figure 3. Fasteners

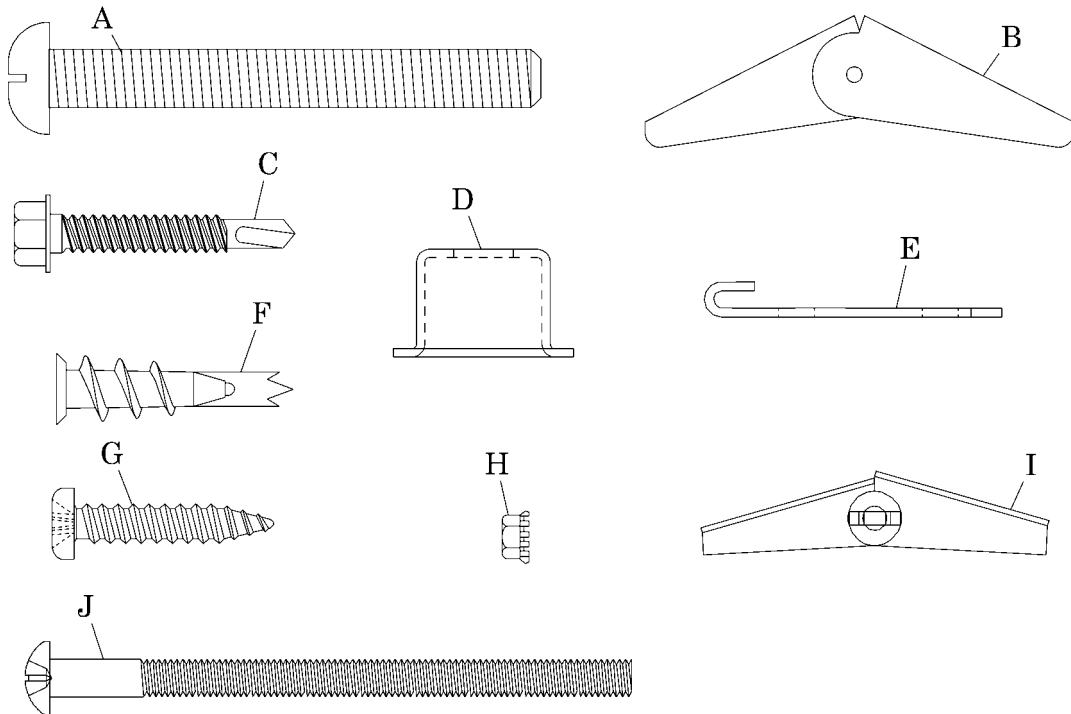

i564a003

- Toggle bolt (A)
- 3/8"-16 toggle wing (B)
- Self-drilling screw (C)
- Stud guide (D)
- Bottom retainer (E)
- E-Z Ancor¹ screw anchor (F)
- Pan head screw (G)
- Locknut (H)
- Toggle wing (I)
- 3" round head screw (J)

1. E-Z Ancor[®] is a registered trademark of Illinois Tool Works, Inc.

Determining the Wall/Construction Type



WARNING:

The installation method differs for each wall and construction type. Failure to determine the wall and construction type could result in personal injury or equipment damage.

1. Before proceeding, refer to the local or state building codes, and determine the type of wall and construction type:
 - **Seismic** walls are constructed to prevent damage from an earthquake.
 - **Non-seismic** walls are **not** constructed to prevent damage from an earthquake.
2. Do **one** of the following:
 - For **seismic** walls, install wall backing plates according to the Office of State-wide Health, Planning, and Development (OSHPD) approved drawings and the as-built drawings.



WARNING:

When installing the Horizon® Headwall System on **non-seismic-rated** dry wall, make sure the walls are constructed of at least 20-gauge steel studs on 16" (41 cm) centerlines and covered with a minimum of 5/8" (16.0 mm) dry wall. Failure to do so could result in the collapse of the Horizon® Headwall System. Personal injury or equipment damage could occur.

- For **non-seismic** walls, make sure the walls are constructed of at least 20-gauge steel studs on 16" (41 cm) centerlines and covered with a minimum of 5/8" (16.0 mm) dry wall.

Installing the Rough-in Box(es) (P1034)

1. Refer to the as-built drawings for required dimensions and particulars, such as which end of the raceways to locate the rough-in boxes (K) and medical gas drops (L), the services required, and necessary clearances (see figure 4 on page 8).

NOTE:

The **dimensions** shown in the rough-in illustrations **must** be correct to make sure the hose panels and optional raceway-attached accessories fit correctly.

2. On the wall stud (M), set each rough-in box (K) with its mounting strap (N) toward the outside end of the applicable raceway:
 - Bottom raceway (O)
 - Gas raceway (P)
 - Light raceway (Q)
3. If the finished floor (R) is **not** installed, establish its thickness, and make adjustments to comply with the dimensions shown in the figure. Allow for side wall clearance or wall obstructions that might interfere with the raceway (O), (P), or (Q) and the length of the wire extending from the back of the raceway (O), (P), or (Q).

NOTE:

If the wire length extending out of the back of the raceway is **not** specified, use the following equation:

Ceiling height - Distance of the raceway off the finished floor + 24" (60 cm) = Wire length extending out the back of the raceway

4. Install two self-drilling screws (C) to secure the mounting strap (N) each rough-in box (K) to the wall stud so the face of the rough-in box (K) is flush with the finished wall surface (S) (see figure 5 on page 9) (see view T).
5. Use 1¼" conduit (U) between the rough-in boxes (K).

Figure 4. Rough-in Box Installation

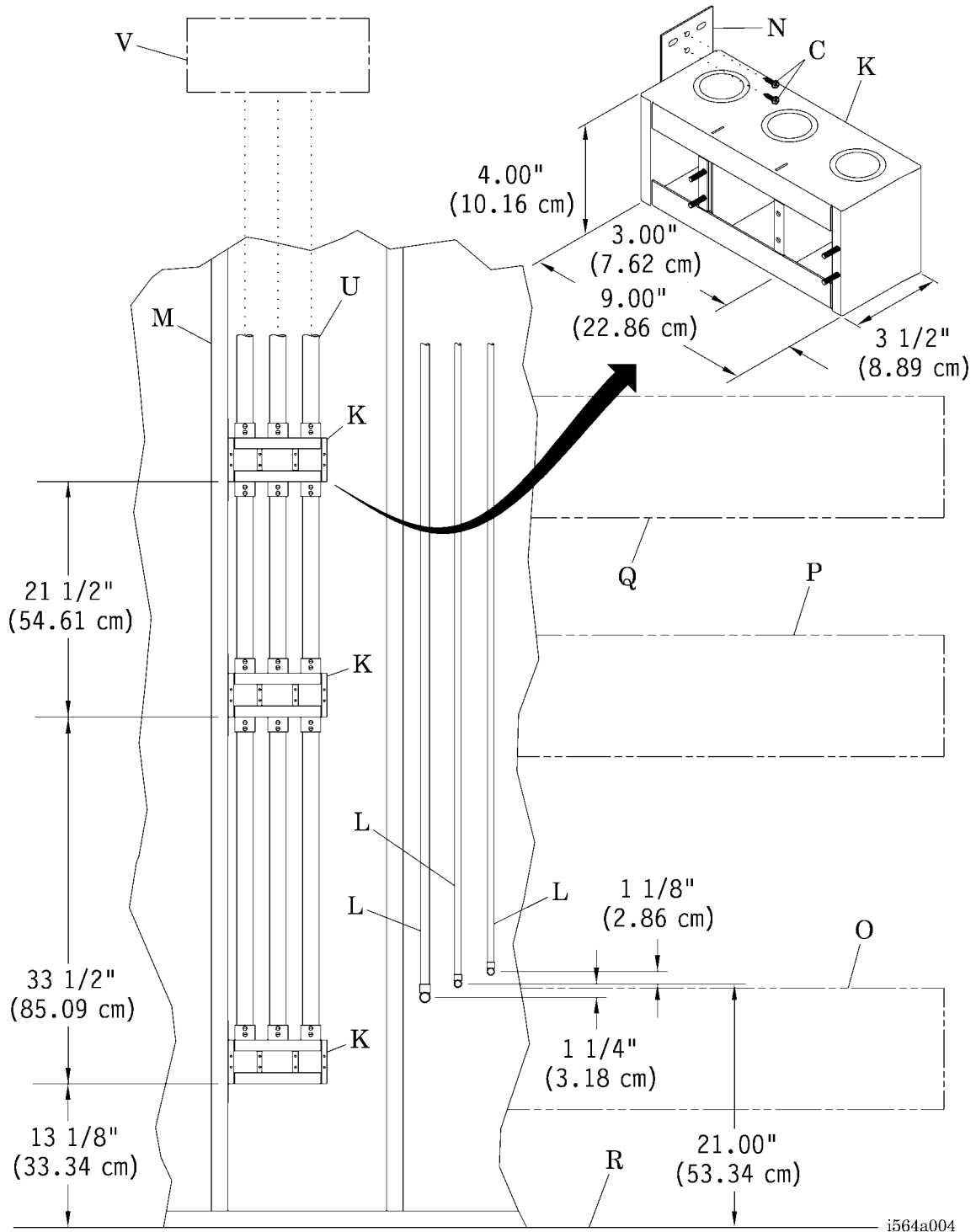

i564a004

Figure 5. Medical Gas Drops

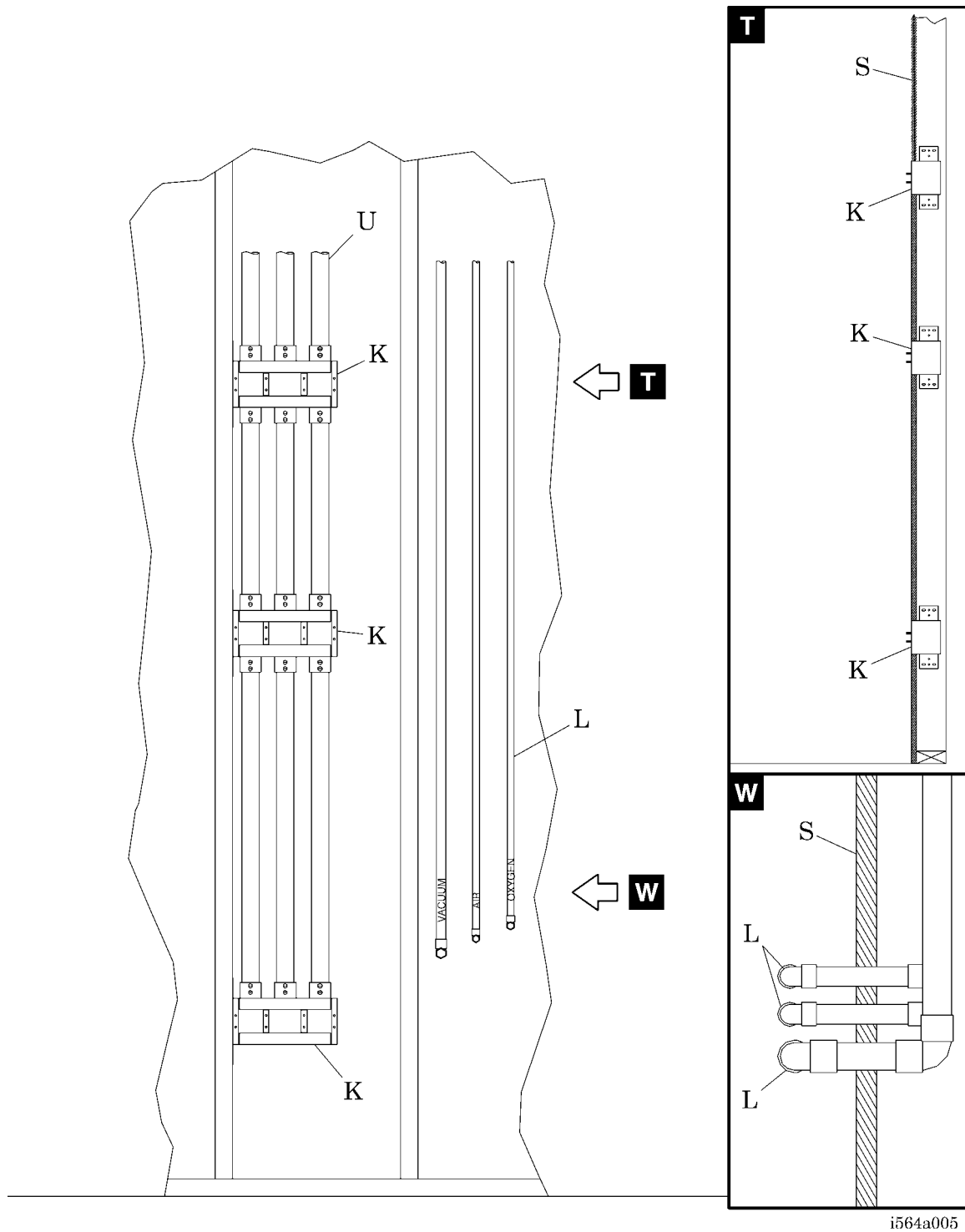

Making the Electrical and Gas Services Drops



SHOCK HAZARD:

Make sure no electrical power is supplied to the facility wiring. Personal injury or equipment damage could occur.

1. Make sure no electrical power is supplied to the facility wiring.
2. Have the **installing contractor** do the following:
 - a. Make the conduit (U) drop from the junction box (V) above the ceiling line to the rough-in boxes (K) (see figure 4 on page 8). Make sure the conduit (U) running between the above-ceiling junction box (V) and the lowest raceway rough-in box (K) is **not** more than 108" (274 cm).

NOTE:

When field conduit connections are installed in concentric knockouts that are punched to impair the electrical connection of the raceway system to ground, the contractor must install #10 American Gauge Wire (AWG) ground jumpers. The ground jumpers must meet the requirements of Article 250 of NEC®¹. The ground jumpers must connect from the reference ground point to the grounding bushings on the conduit connectors. The electrical contractor will provide the jumpers and ground bushings.



WARNING:

Make sure the medical gas lines are in the correct orientation for connecting to the manifold assembly. If gases are cross-connected, personal injury or death could occur.

- b. Make the medical gas drops (L) according to the as-built drawings (see figure 5 on page 9) (see view W).
- c. Complete the wall construction and finished wall surface (S).
- d. Confirm the designated areas for line voltage and emergency power from the as-built drawings, and pull the wiring for line voltage standard and emergency power circuits. Leave 18" (46 cm) of free length in the above-ceiling junction box (V) (see figure 4 on page 8).

NOTE:

If the volume of emergency power wiring exceeds line voltage wiring, the designated areas for line voltage and emergency power may be reversed.

1. NEC® is a registered trademark of National Fire Protection Association, Inc.

Installing the Medical Gas Manifold

NOTE:

Each bed position in a patient room requires a manifold assembly. The **installing contractor** supplies the required fittings and piping between manifold assemblies.

1. Refer to the as-built drawings for the manifold centerline, and mark a level vertical line (X) on the wall to show the centerline (see figure 6 on page 12).
2. Set the manifold assembly (Y) on the wall:
 - Make sure the centerline label is centered on the vertical line (X).
 - Make sure the bottom of the lowest tube is at least 20" (51 cm) from the finished floor (R).
 - Make sure the top of the highest tube is no more than 25" (64 cm) from the finished floor (R).
3. On the wall, mark the locations of the holes of the hanger brackets (Z) on the manifold assembly (Y).



SHOCK HAZARD:

Make sure no electrical power is supplied to the facility wiring. Personal injury or equipment damage could occur.

4. Disconnect and tag all electrical power from any wiring behind the wall(s) where the manifold assembly (Y) will be mounted.
5. To secure the manifold assembly (Y) to the wall, do **one** of the following:
 - For **seismic-rated** dry wall, install the self-drilling screws (C) (see figure 3 on page 5) to secure the manifold assembly (Y) to the backing plate or wall stud (see figure 6 on page 12).
 - For **non-seismic-rated** dry wall, install the toggle wings (I) and 3" round head screws (J) (see figure 3 on page 5) to secure the manifold assembly (Y) to the wall (see figure 6 on page 12).



CAUTION:

If the medical gas drops are **not** located correctly, have the **installing contractor** relocate them. Failure to do so could result in equipment damage.

6. Make sure the medical gas drops (L) are located correctly (see figure 5 on page 9). If necessary, have the **installing contractor** relocate them.

Figure 6. Manifold Assembly

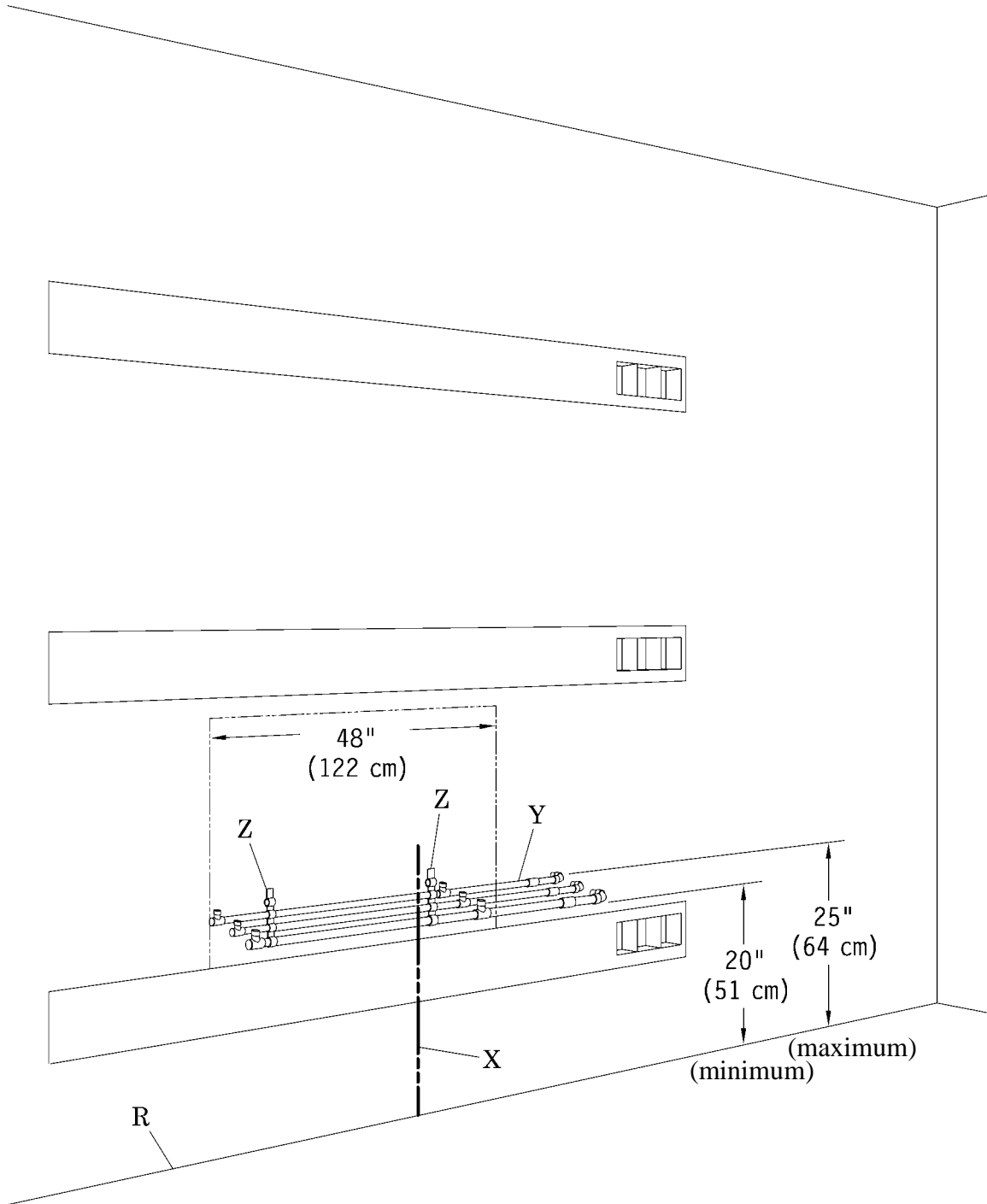

i564a006

7. Connect the copper tube fittings from the manifold assembly (Y) (see figure 6 on page 12) to the medical gas service drops (L) according to applicable state and local codes, and the following (see figure 5 on page 9).
 - NFPA 99, *Standards for Health Care Facilities*
 - CSA Z305.1, *Non-Flammable Medical Gas Piping Systems*
 - CSA Z318.5, *Commissioning of Electrical Gas Equipment and Standards in Health Care Facilities*
 - CSA Z318.6, *Commissioning of Medical Gas Systems in Health Care Facilities*

Installing the Raceway Hanger Brackets

NOTE:

The horizontal raceway sections are of varying lengths and may be installed next to each other to span greater lengths. Your installation may not require all types. For specific details, refer to your as-built drawings.

1. Find the rough-in box (K) (see figure 7 on page 13).

Figure 7. Raceway Hanger Installation

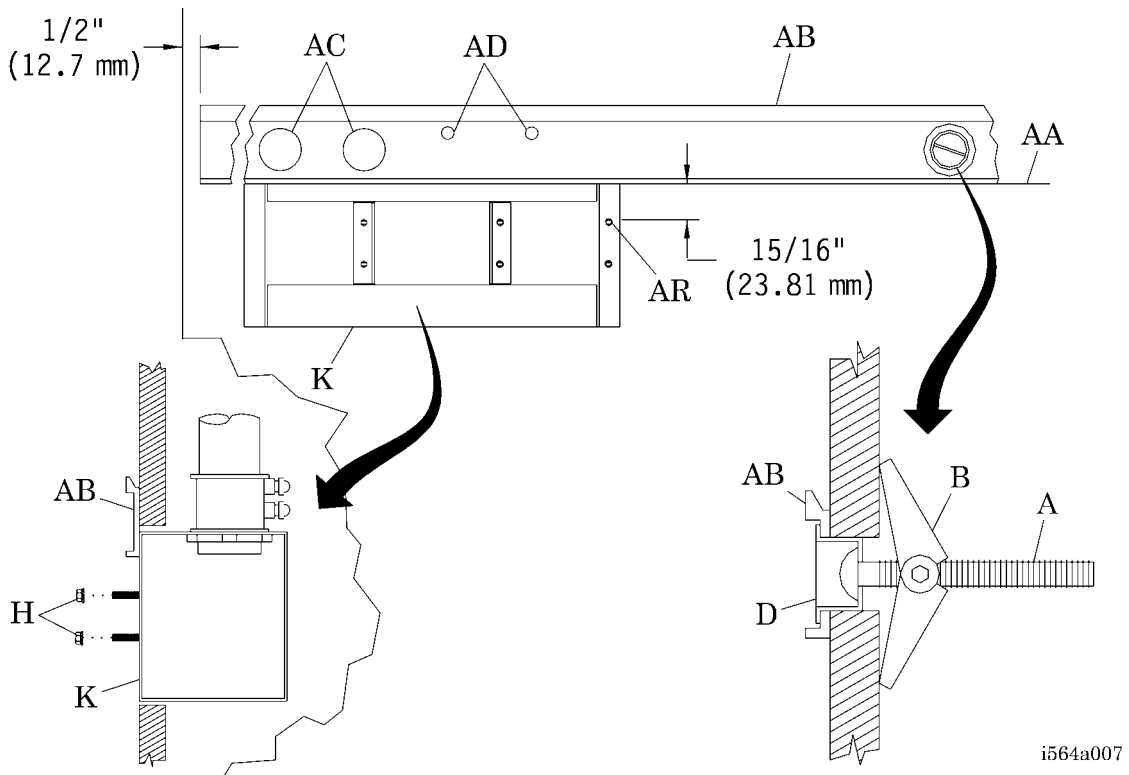

2. Measure up 15/16" (23.81 mm) from the upper hole/stud (AR) in the rough-in box (K), and make a mark on the wall.
3. For each raceway, use a 4' (122 cm) level to strike a horizontal chalkline (AA) on the wall at least as long as the raceway. Maintain correct spacing between chalklines (AA) for the full length.
4. Set a section of the raceway hanger bracket (AB) on the wall with the **bottom** flush with the chalkline (AA).
5. For **non-seismic-rated** dry wall, do the following:
 - a. Trace the pairs of 1" diameter holes (AC) to indicate the location of the mounting holes.



SHOCK HAZARD:

Make sure no electrical power is supplied to the facility wiring. Personal injury or equipment damage could occur.

- b. Disconnect and tag all electrical power from any wiring behind the wall(s) where the horizontal raceway will be mounted.



WARNING:

Wear eye protection. Failure to do so could result in eye injury.

- c. Put on safety glasses.
- d. Drill only one 15/16" (28.1 mm) hole in the dry wall at each pair of 1" diameter holes (AC). If an obstruction or wall stud is encountered, drill at the second hole location.
- e. Clean up any debris from drilling.
- f. Set a section of the raceway hanger bracket (AB) on the wall with the **bottom** flush with the chalkline (AA).
- g. Install the toggle bolts (A), 3/8"-16 toggle wings (B), and stud guides (D) at the 1" (3 cm) diameter holes (AC) to secure the raceway hanger brackets (AB) to the wall (see figure 7 on page 13).

6. For **seismic-rated** dry wall, do the following:
 - a. Mark the location of the pre-drilled holes (AD) (see figure 7 on page 13).



SHOCK HAZARD:

Make sure no electrical power is supplied to the facility wiring. Personal injury or equipment damage could occur.

- b. Disconnect and tag all electrical power from any wiring behind the wall(s) where the horizontal raceway will be mounted.
 - c. Set a section of the raceway hanger bracket (AB) on the wall with the **bottom** flush with the chalkline (AA).
 - d. install the self-drilling screws (C) (see figure 3 on page 5) at the pre-drilled holes (AD) to secure the raceway hanger brackets (AB) to the backing plates (see figure 7 on page 13).
7. Make sure the additional raceway hanger brackets (AB) are level with the first raceway hanger bracket (AB) and that no space exists between them (see figure 7 on page 13).
8. If the wall has waviness more than 1/16" (1.6 mm) per foot, do the following:
 - a. Loosen the self-drilling screws (C) or toggle bolts (A) at the low spot(s) (see figure 3 on page 5).
 - b. Shim behind the raceway hanger bracket (AB).
 - c. Tighten the self-drilling screws (C) or toggle bolts (A).

Installing the Horizontal Raceways

1. Find the section of the raceway (O), (P), or (Q) that has openings in the back side (see figure 8 on page 16).

Figure 8. Raceway Installation

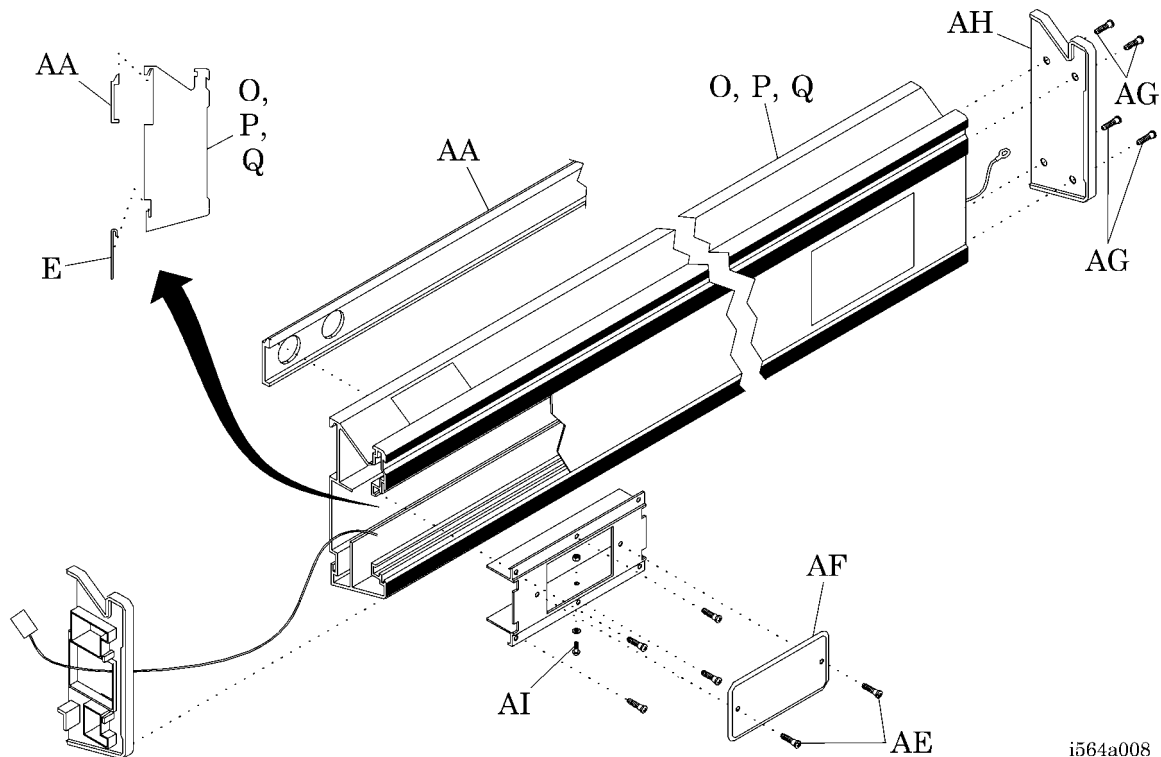

2. Remove the two screws (AE) that secure each blank faceplate (AF) to the front of the raceway (O), (P), or (Q).
3. Remove the blank faceplates (AF) from the raceway (O), (P), or (Q).
4. Pull the wires and cables through the rough-in box (K) and conduit (U) to the above-ceiling junction box (V) (see figure 4 on page 8):
 - Make no wire connections in the rough-in box (K).
 - Connect the green ground conductor of each raceway (O), (P), or (Q) to the ground in the above-ceiling junction box (V).
 - If the termination conduit (U) is smaller than 1¼" trade size, pull #10 AWG minimum ground wire through the grounding bushings.

5. Set the raceway (O), (P), or (Q) over the raceway hanger bracket (AB) (see figure 8 on page 16):
 - Make sure the raceway (O), (P), or (Q) engages the raceway hanger bracket (AB).
 - Align the studs in the rough-in box (K) with the slots in the raceway (O), (P), or (Q) (see figure 4 on page 8).
6. Evenly space bottom retainers (E) in the lower rear groove of the raceway (O), (P), or (Q) (see figure 8 on page 16):
 - On **9' (274 cm)** sections, use **three** bottom retainers (E).
 - On sections **shorter than 9' (274 cm)**, use **two** bottom retainers (E).



SHOCK HAZARD:

Make sure no electrical power is supplied to the facility wiring. Personal injury or equipment damage could occur.

7. Disconnect and tag all electrical power from any wiring behind the wall(s) where the raceway (O), (P), or (Q) will be mounted.
8. Install the E-Z Ancor®¹ screw anchors (F) and pan head screws (G) to secure the bottom retainers (E) to the wall (see figure 3 on page 5).

or

If exposed bottom retainers (E) are **not** desired, do the following (see figure 8 on page 16):

- a. Remove the four screws (AG) that secure each endplate (AH) or device at each end of the sections of raceway (O), (P), or (Q).



WARNING:

Wear eye protection. Failure to do so could result in eye injury.

- b. Put on safety glasses.
- c. Protect any wiring, and drill ¼" holes through the back of the raceway (O), (P), or (Q).

1. E-Z Ancor® is a registered trademark of Illinois Tool Works, Inc.

- d. At the holes drilled in step b, secure the raceway (O), (P), or (Q) to the wall:
 - On **non-seismic-rated** dry wall, install the toggle wings (I) and 3" round head screws (J) (see figure 3 on page 5).
 - On **seismic-rated** dry wall, install the self-drilling screws (C) (see figure 3 on page 5).
- e. Install the four screws (AG) to secure each endplate (AH) or device at each end of the sections of raceway (O), (P), or (Q) (see figure 8 on page 16).
9. Through the openings in the raceway (O), (P), or (Q) (see figure 8 on page 16), install the locknuts (H) on the threaded studs in the rough-in box (K) (see figure 7 on page 13) to secure the raceway (O), (P), or (Q) to the wall.
10. Make the connections for line voltage and emergency power circuits.



CAUTION:

After making electrical plug connections between the horizontal raceways, visually examine for correct mating positions. Failure to make a good connection could result in heat buildup, smoke, and interruption of power.

11. Visually examine the connections for correct mating positions (see figure 9 on page 18).

Figure 9. Electrical Plug Connection Mating Positions

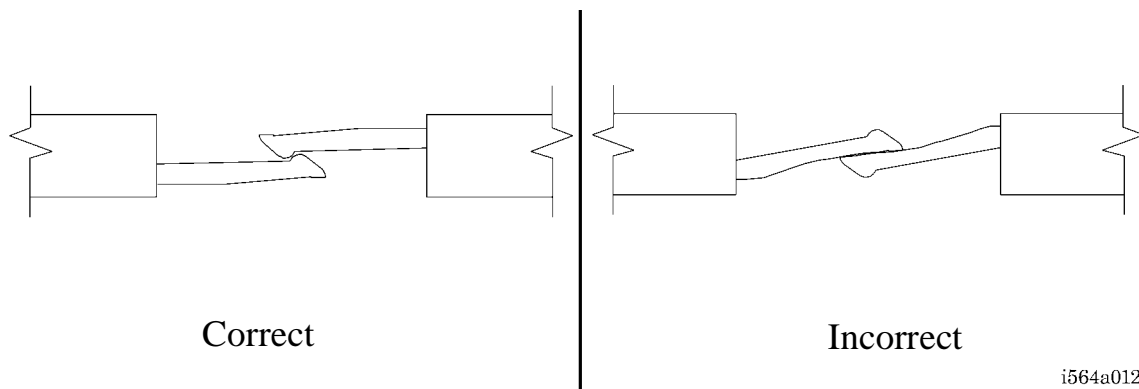

12. Connect the ground wires.
13. Check continuity between the farthest ground receptacle of each raceway (O), (P), or (Q) and ground (see figure 8 on page 16).
14. Route all signalling circuit wires and cabling to the appropriate raceway (O), (P), or (Q).
15. Attach the signalling circuit wires and cabling to pull cords, and pull them into the appropriate backbox.

Installing Additional Horizontal Raceway Sections

When more than one section of raceway (O), (P), or (Q) is required for length, do the following for **all** sections of the raceway (O), (P), or (Q) (see figure 8 on page 16):

1. Find the next section of raceway (O), (P), or (Q).
2. At the end toward the power input, remove the two screws (AE) that secure each blank faceplate (AF) to the front of the raceway (O), (P), or (Q).
3. Remove the blank faceplates (AF) from the raceway (O), (P), or (Q) to expose the ground stud (AI).
4. Set the section of raceway (O), (P), or (Q) over the raceway hanger bracket (AB), and leave about a 3" (8 cm) gap between the two sections of raceway (O), (P), or (Q).
5. Route the ground wire from the first section of raceway (O), (P), or (Q), located next to the power input, into the next section of raceway (O), (P), or (Q).
6. Connect the ground wire to the ground stud (AI).
7. Make connections for the line voltage and emergency power circuits.
8. Tie the ends of the pull cords together.
9. Slide the section of raceway (O), (P), or (Q) toward the next section of raceway (O), (P), or (Q) until the plastic sleeve seats securely.
10. Evenly space bottom retainers (E) in the lower rear groove of the raceway (O), (P), or (Q):
 - On **9' (274 cm)** sections, use **three** bottom retainers (E).
 - On sections **shorter than 9' (274 cm)**, use **two** bottom retainers (E).
11. Install the E-Z Ancor®¹ screw anchors (F) and pan head screws (G) to secure the bottom retainers (E) to the wall (see figure 3 on page 5).

or

If exposed bottom retainers (E) are **not** desired, do the following (see figure 8 on page 16):

- a. Remove the four screws (AG) that secure each endplate (AH) or device at each end of the sections of raceway (O), (P), or (Q).

1. E-Z Ancor® is a registered trademark of Illinois Tool Works, Inc.



WARNING:

Wear eye protection. Failure to do so could result in eye injury.

- b. Put on safety glasses.
- c. Protect any wiring, and drill ¼" holes through the back of the raceway (O), (P), or (Q).
- d. At the holes drilled in step b, secure the raceway (O), (P), or (Q) to the wall:
 - On **non-seismic-rated** dry wall, install the toggle wings (I) and 3" round head screws (J) (see figure 3 on page 5).
 - On **seismic-rated** dry wall, install the self-drilling screws (C) (see figure 3 on page 5).
- e. Install the four screws (AG) to secure each endplate (AH) or device at each end of the sections of raceway (O), (P), or (Q) (see figure 8 on page 16).

Installing the Hose Panels

1. Before installing the hose panels (AJ), make sure they are correctly identified (see figure 10 on page 21).
2. Refer to the as-built drawings, and find the hose panel (AJ) that is to be installed first.

NOTE:

The manifold access panel has sliding latches on the top edge only and **must** be installed last.

3. Put the Z-bracket (AK) into the slot projecting from the top of the bottom raceway (O) (see view AL).
4. Rotate the hose panel (AJ) up to the full vertical position, and mark the outer hole positions for the panel mounting brackets (AM).
5. Remove the hose panel (AJ) from the bottom raceway (O) (see view AL).
6. Remove the panel mounting brackets (AM) from the hose panels (AJ).
7. Set the panel mounting brackets (AM) over the previously marked hole positions, and mark the remaining holes.



SHOCK HAZARD:

Make sure no electrical power is supplied to the facility wiring. Personal injury or equipment damage could occur.

8. Disconnect and tag all electrical power from any wiring behind the wall(s) where the hose panels (AJ) will be mounted.

Figure 10. Hose Panel

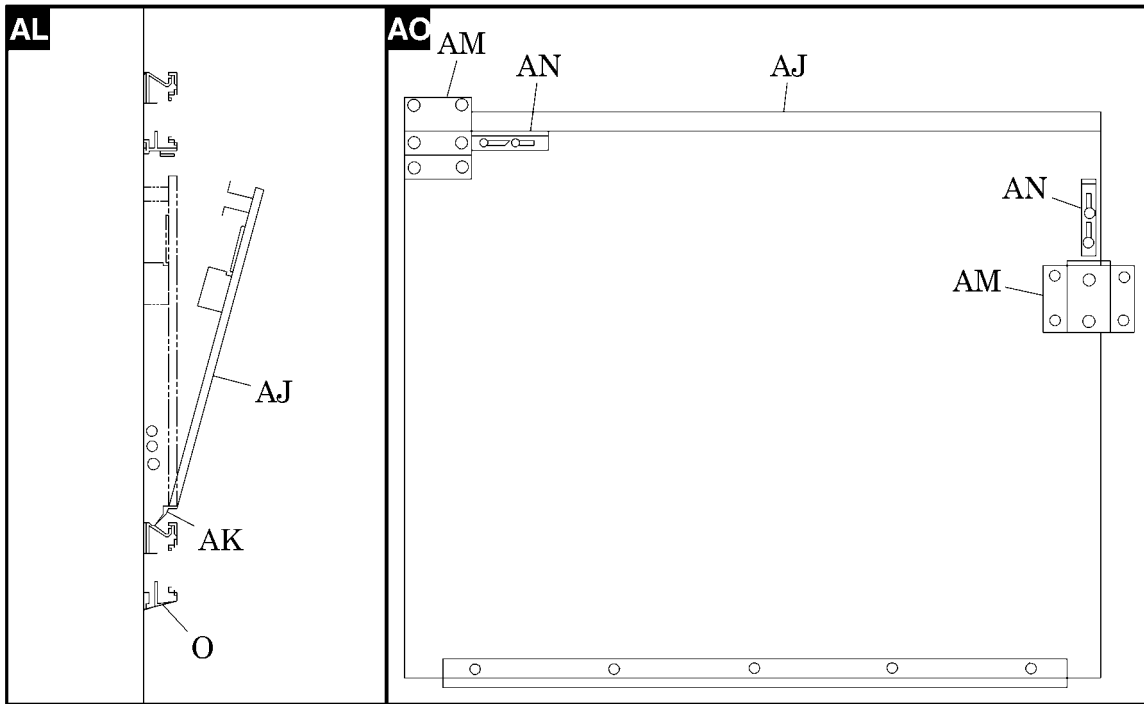
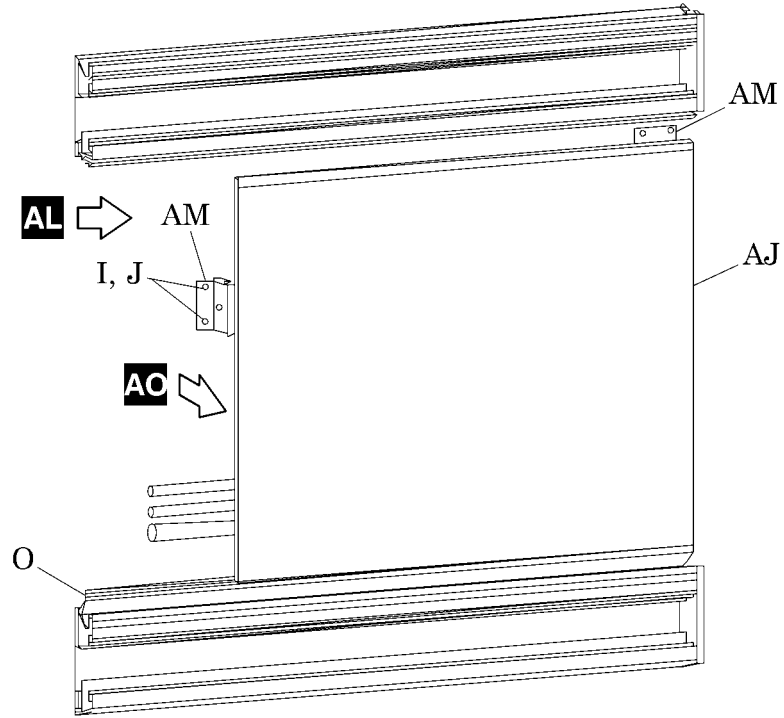

i564a009

9. Install the toggle wings (I) and 3" round head screws (J) to secure the panel mounting brackets (AM) to the wall.
10. Remove the screws from the hose panel (AJ) that held the panel mounting brackets (AM) in place.
11. Install the hose panel (AJ) on the bottom raceway (O), and slide the latches (AN) under the panel mounting brackets (AM) to secure the hose panel (AJ) in place (see view AO).
12. Find the **center** hose panel (AJ), and set it **temporarily** in position as a spacer for the outer panel. Leave 1/16" (1.6 mm) clearance between panels.

NOTE:

The center hose panel has two sliding latches on the upper back side of the trim edge.

13. Repeat step 3 through step 11 for the outer panel.
14. Set the **center** hose panel (AJ) between the two outer hose panels (AJ):
 - a. Set the Z-bracket (AK) into the top slot on the bottom raceway (O) (see view AL).
 - b. Rotate the hose panel (AJ) up to the full vertical position.
15. Slide the two latches outward and under the edge of the adjacent hose panels (AJ) to secure the center panel in position.

Connecting the Medical Gas Outlets

1. For the quantity and type of medical gas outlets to be installed, refer to the as-built drawings.
2. Remove the manifold access panel to expose the manifold assembly (Y) (see figure 11 on page 23).

Figure 11. Gas Outlet

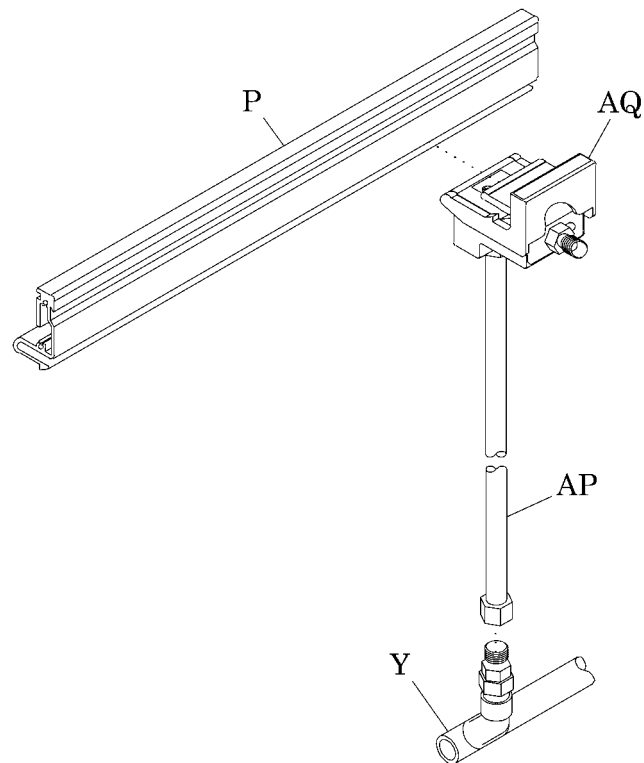

i564a010

NOTE:

To help prevent cross connection between gases, the manifold assembly and hose connections are provided with diameter index safety system (DISS) indexing.



CAUTION:

Make sure hoses are not twisted or crimped behind the hose panels. Improper gas delivery or hose damage may result.



CAUTION:

Finger-tighten the medical gas hoses connections to the manifold assembly. Over-tightening could result in fitting damage.



WARNING:

Do not force a hose onto a connection that is not exactly mated. **Do not** change connectors to another type on outlets or hoses. Personal injury or death could result.

3. Connect the outlet and hose assembly (AP) to the manifold assembly (Y).
4. Connect the gas outlet block (AQ) to the gas raceway (P).