

Subject: Flatwall Headwall System Hanger (P671E)—Installation Instructions

Introduction

This procedure provides instructions for installing the Flatwall Headwall System Hanger (P671E). Before starting this procedure, read and understand all of the instructions for the parts being installed. Refer to the as-built drawings for the particular unit being installed. The as-built drawings take precedence over these instructions.

Tools required:

As-built drawings	Chalk line
Level	Pencil
#2 phillips head screwdriver	Safety glasses
Electric drill or power screwdriver	1" drill bit
Broom	Dustpan
5/16" socket wrench	

Parts required:

(1)	Reference only	Hanger assembly—19", 28", or 37"
and		
(1)	52377	Bag assembly (19" hanger)
or		
(1)	52378	Bag assembly (28" hanger)
or		
(1)	52376	Bag assembly—670 Flatwall Headwall System (37" hanger)

52377 (Bag assembly (19" hanger)), 52378 (Bag assembly (28" hanger)), and 52376 (Bag assembly—670 Flatwall Headwall System (37" hanger)) include the following items:

(2 to 4)	21045	Toggle bolt
(4, 6, or 8)	53143-01	Screw, #12, self-drilling, hex head
(2 to 4)	50815	Nut
(2 to 4)	29325	Stud guide
(2 to 4)	21046	Toggle wing

Related Documents: [Flatwall Headwall System \(P670E\)—Installation Instructions \(is797\)](#)

Preparing the Wall for Installation



WARNING:

The installation method differs for each wall and construction type. Failure to determine the wall and construction type could result in the collapse of the Flatwall Headwall System. Personal injury or equipment damage could occur.

1. Before proceeding, refer to the local or state building codes, and determine the wall type and construction type:
 - **Seismic** walls are constructed to prevent damage from an earthquake.
 - **Non-seismic** walls are **not** constructed to prevent damage from an earthquake.
 - **Fire-rated** walls are constructed to prevent the spread of fire.
 - **Non-fire-rated** walls are **not** constructed to prevent the spread of fire.
2. Do **one** of the following:
 - For **seismic** walls, install wall backing plates according to the California Office of Statewide Health, Planning, and Development (OSHPD)-approved drawings and the as-built drawings.
 - For **non-seismic** walls (both **fire-rated** and **non-fire-rated**), make sure the walls are constructed with at least 20-gauge steel studs on 16" centers and covered with a minimum of 5/8" (15.875 mm) drywall.

Installing the Hanger Assembly

1. Refer to the as-built drawings, and make sure the services needed by the Flatwall Headwall System are available in the rough-in areas for connection.
2. Do the following:
 - a. Find and strike the centerline (A) for the Flatwall Headwall System (see figure 1 on page 3).

Figure 1. Hanger Assembly

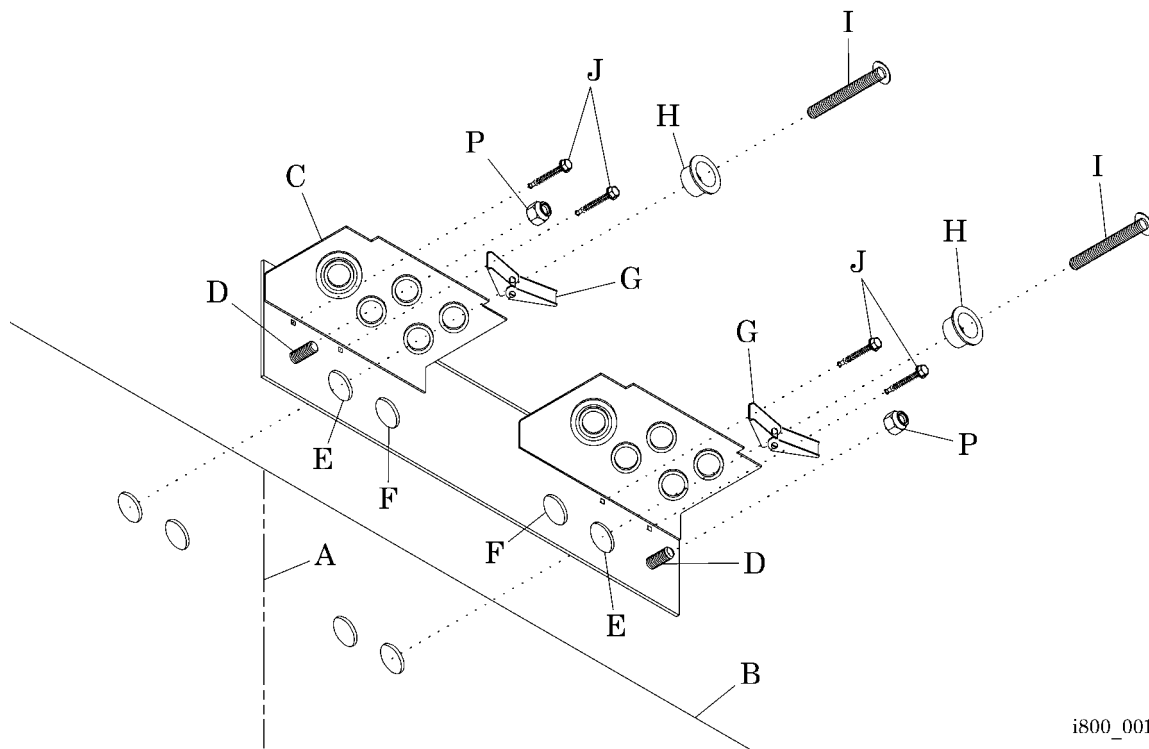

i800_001

- b. If the finished ceiling is **not** installed, find and strike the ceiling line (B).
3. Set the hanger assembly (C) on the centerline (A) so its top edge is at the ceiling line (B).
 4. Make sure the centers of the studs (D) on the hanger assembly (C) are level.
 5. For **non-fire-rated** or **non-seismic** walls, do the following:
 - a. Using the hanger assembly (C) as a guide, mark the location of the primary holes (E) and secondary holes (F) on the wall.



WARNING:

Wear eye protection. Failure to do so could result in eye injury.

- b. Put on safety goggles.
 - c. At the locations of the primary holes (E), drill a hole through the plaster board.
 - d. If a stud or an obstacle is at a primary hole (E), drill at the location of the nearest secondary hole (F).
 - e. Install the toggle wings (G), stud guides (H), and toggle bolts (I) to secure the hanger assembly (C) to the wall.
 - f. Clean up any debris from drilling.
6. On **fire-rated** or **seismic** walls, install the self-drilling screws (J) to secure the hanger assembly (C) to the backing plate and/or wall studs.
 7. For dimensions of the hardware installation hole pattern in relation to the centerline (A), ceiling line (B), primary holes (E), secondary holes (F), and locations of the self-drilling screws (J), refer to the appropriate figure:
 - For a 19" (48 cm) unit, refer to figure 2 on page 5.
 - For a 28" (71 cm) unit, refer to figure 3 on page 5.
 - For a 37" (94 cm) unit, refer to figure 4 on page 5.
 8. Refer to the as-built drawings for the medical gas tubing size and location, and have the **medical gas contractor** make the medical gas drops to the appropriate location. Make sure the ends of the medical gas drops are at least 6" (15 cm) above the knockout plate of the hanger assembly (C) (see figure 1 on page 3).
 9. Refer to the as-built drawings for the electrical services junction box location, and have the **electrical contractor** remove the appropriate knockouts (K) and/or (L) and install the service drop conduit:
 - For a 19" (48 cm) unit, refer to figure 5 on page 6.
 - For a 28" (71 cm) unit, refer to figure 6 on page 6.
 - For a 37" (94 cm) unit, refer to figure 7 on page 7.
- NOTE:**
The concentric knockouts have two different sizes: ½" x ¾" (12.7 mm x 19.1 mm) **or** ½" x ¾" x 1" x 1 ¼" (12.7 mm x 19.1 mm x 3 cm x 3.18 cm).
10. The **electrical contractor** may pull in the wiring for normal power (M) and critical branch or emergency power (N) as required, leaving approximately 18" (46 cm) of free length. For the positioning of the normal power (M) and critical branch or emergency power (N), refer to the as-built drawings.

Figure 2. Hole Pattern—19" Unit

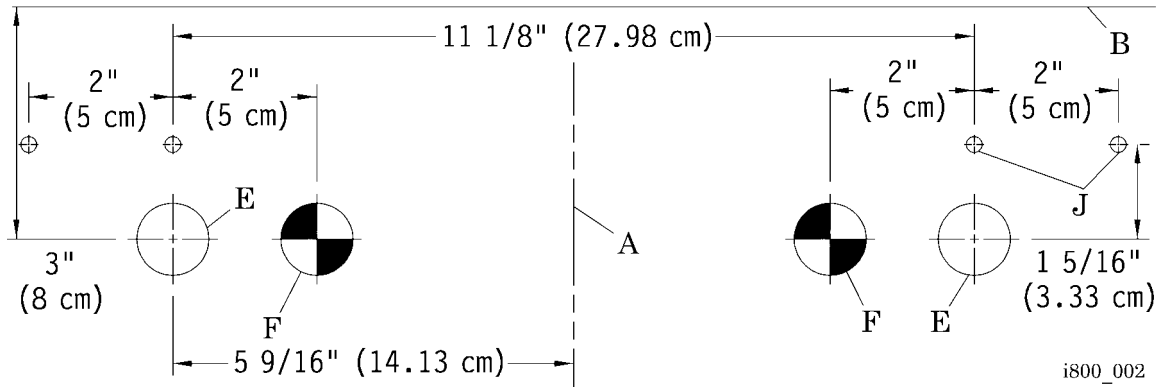

i800_002

Figure 3. Hole Pattern—28" Unit

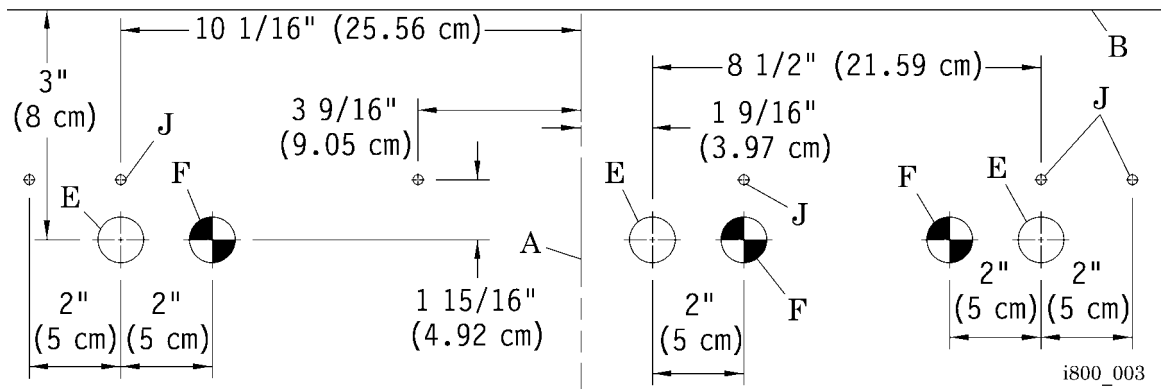

i800_003

Figure 4. Hole Pattern—37" Unit

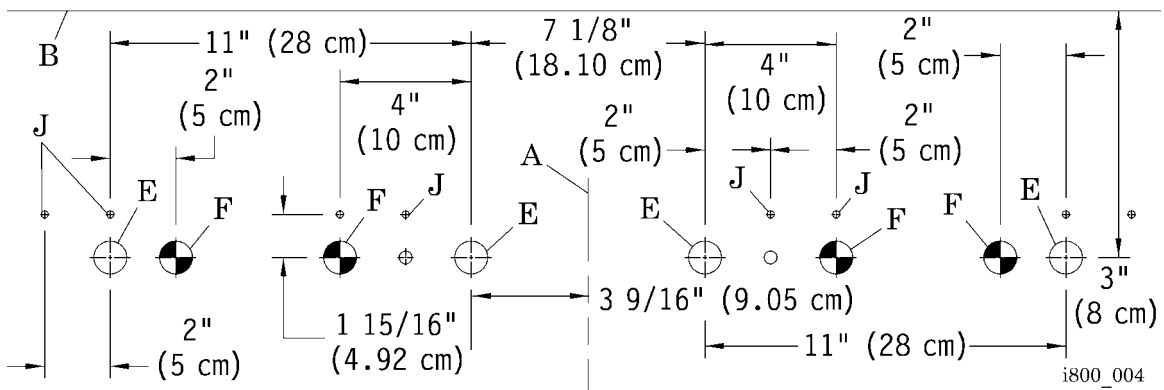

i800_004

Figure 5. Knockout Locations—19" Unit

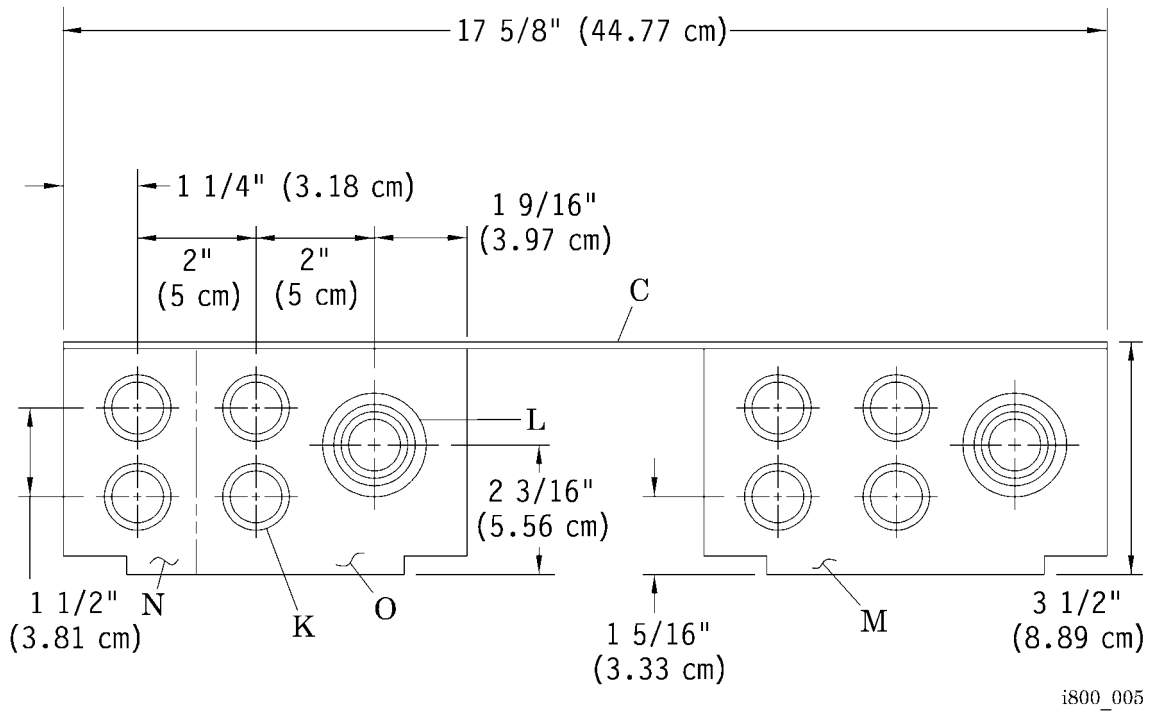

Figure 6. Knockout Locations—28" Unit

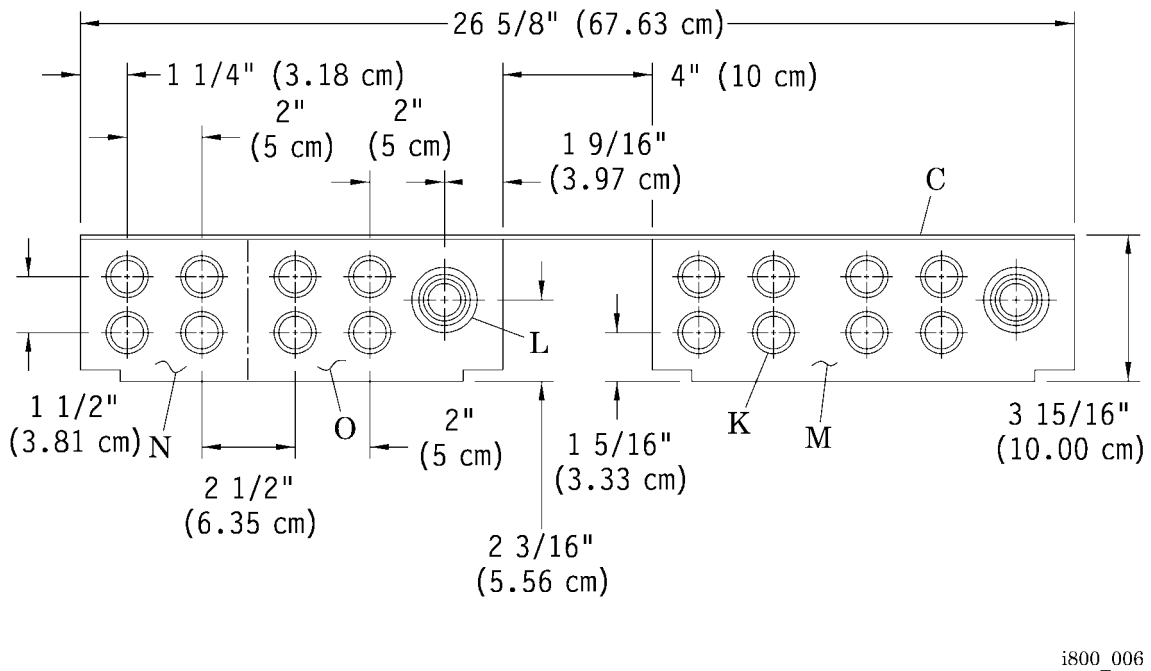
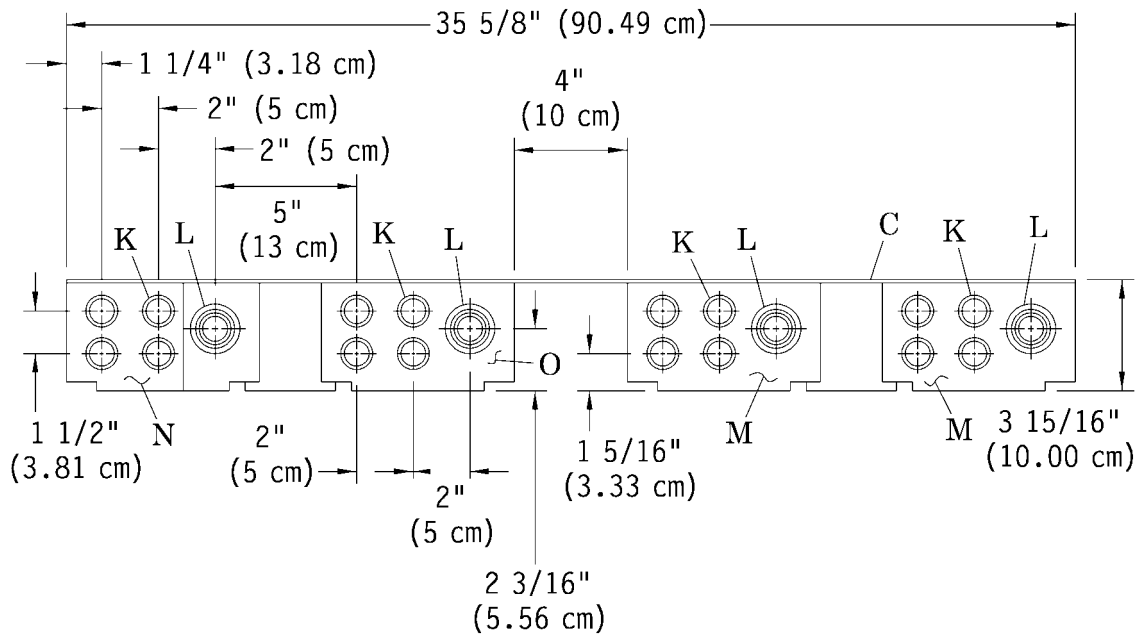

Figure 7. Knockout Locations—37" Unit



i800_007

11. The **electrical contractor** may pull in the wiring for low voltage power (O) such as Nurse Call or telephone as required, but the free length must be considered from the equipment location shown in the as-built drawings.

NOTE:

When the field conduit connectors are installed in concentric knockouts that are punched to impair the electrical connection of the raceway system to the ground, the **electrical contractor** must install #10 American Wire Gauge (AWG) ground jumpers from the reference ground point to the grounding bushings on the conduit connectors. The ground jumpers must meet the requirements of Article 250 of the National Fire Protection Association 70, *National Electrical Code*¹ (NEC^{®2}). The **electrical contractor** must provide the ground jumpers and ground bushings.

12. Make sure the knockout plates of the hanger assembly (C) remain level (see figure 1 on page 3).
13. If necessary, have the **installing contractor** apply the wall finish.
14. Install the nuts (P) on the studs (D) of the hanger assembly (C).

1. National Electrical Code[®] is a registered trademark of National Fire Protection Association, Inc.
2. NEC[®] is a registered trademark of National Fire Protection Association, Inc.

15. Install the Flatwall Headwall System (P670E). Refer to the *Flatwall Headwall System (P670E)—Installation Instructions (is797)*.