

INSTALLATION INSTRUCTIONS

Horizon® Headwall System + Vertical Chase (with and without a Breaker Panel)

From Hill-Rom



Product No. P1000

For Parts or Technical Assistance
Technical Support: (800) 445-3720
Customer Service: (800) 445-3730
Canada: (800) 267-2337
International: Contact your distributor.
www.hill-rom.com

is563

Horizon® Headwall System + Vertical Chase (with and without a Breaker Panel) Installation Instructions

Revision Letter	Pages Affected	Date
Original Issue		December, 2001

is563

© 2001 by Hill-Rom Services, Inc. ALL RIGHTS RESERVED.

No part of this text shall be reproduced or transmitted in any form or by any means, electronic or mechanical, including photocopying, recording, or by any information or retrieval system without written permission from Hill-Rom Services, Inc. (Hill-Rom).

The information in this manual is confidential and may not be disclosed to third parties without the prior written consent of Hill-Rom.

First Edition

Printed in the USA

Hill-Rom® is a registered trademark of Hill-Rom Services, Inc.

Horizon® is a registered trademark of Hill-Rom Services, Inc.

National Electrical Code® is a registered trademark of National Fire Protection Association, Inc.

NEC® is a registered trademark of National Fire Protection Association, Inc.

The information contained in this document is subject to change without notice. Hill-Rom makes no commitment to update or keep current, the information contained in this document.

The only product warranty intended by Hill-Rom is the express, written warranty accompanying the bill of sale to the original purchaser. Hill-Rom makes no other warranty, express or implied, and in particular, makes no warranty of merchantability or fitness for a particular purpose.

To order additional copies of this manual:

- Fax your order for part number is563 to Marketing Communications at (812) 934-1324.
- Send an e-mail with your order for part number is563 to ACS Literature Requests@hill-rom.com.

Table of Contents

Introduction	1
Order of Installation	2
Code Compliance	2
Fastener Identification	3
Determine the Wall/Construction Type	3
Install the Vertical Chase Hanger	5
Make the Electrical and Gas Services Drops	6
Install the Medical Gas Manifold	7
Install the Vertical Chase	10
Install the Raceway Hanger Brackets	13
Install the Horizontal Raceways	15
Installing Additional Horizontal Raceway Sections	17
Install the Breaker Panel(s)	18
Lower Breaker Panel	18
Upper Breaker Panel	19
Install the Hose Panels	21
Connect the Medical Gas Outlets	22

NOTES:

Subject: Horizon® Headwall System +Vertical Chase (with and without a Breaker Panel) Installation Instructions

Tools required: Standard drill/power screwdriver Phillips head screwdrivers
 ¼" diameter drill bit 15/16" diameter drill bit
 Ratchet wrench 5/16" socket or wrench
 ½" socket or wrench 9/16" socket or wrench
 Socket extensions Tape measure
 Level Chalk line

Related Documents: [Horizon® Headwall System Service Manual \(man043\)](#)

Introduction

This installation instruction sheet describes how to install the Horizon® Headwall System and, if required, breaker panel(s) (see figure 1 on page 1).

Prior to installation, carefully **read all** of the installation instructions for the components you are installing.

Figure 1. Horizon® Headwall System

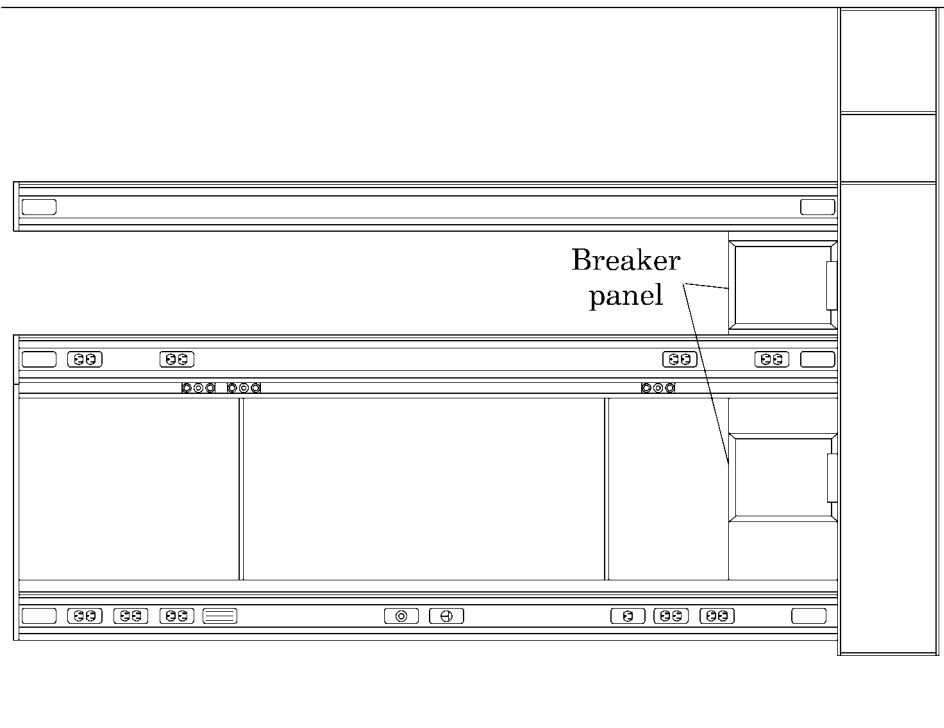

i563_001



WARNING:

For installation of the Horizon® Headwall System (fire-rated/non-seismic), make certain the walls are constructed of at least 20 gauge steel studs on 16" (41 cm) centerlines, and covered with a minimum of 5/8" (15.9 mm) dry wall. Failure to do so could result in the collapse of the Horizon® Headwall System. Personal injury or equipment damage could occur.

Prior to installation of the headwall system components, the facility's medical gases and vacuum lines should have been run to the general location.

Order of Installation

The numbered steps below correspond with the order of installation for the listed components. To identify the listed components, refer to figure 2 on page 3.

1. Determine the wall/construction type
2. Install the vertical chase hanger
3. Make the electrical and gas services drops
4. Install the medical gas manifold
5. Install the vertical chase
6. Install the raceway hanger brackets
7. Install the horizontal raceways
8. Install the breaker panels (if required)
9. Install the hose panels
10. Connect the medical gas outlets

Code Compliance

The installing contractor should follow in all respects the recommendations of the National Fire Protection Association (NFPA 99), National Electrical Code®¹ (NEC®²) Section 370-18, ANSI/NFPA 70, plus state and local codes that apply to this installation.

1. National Electrical Code® is a registered trademark of National Fire Protection Association, Inc.

2. NEC® is a registered trademark of National Fire Protection Association, Inc.

Figure 2. Component Identification

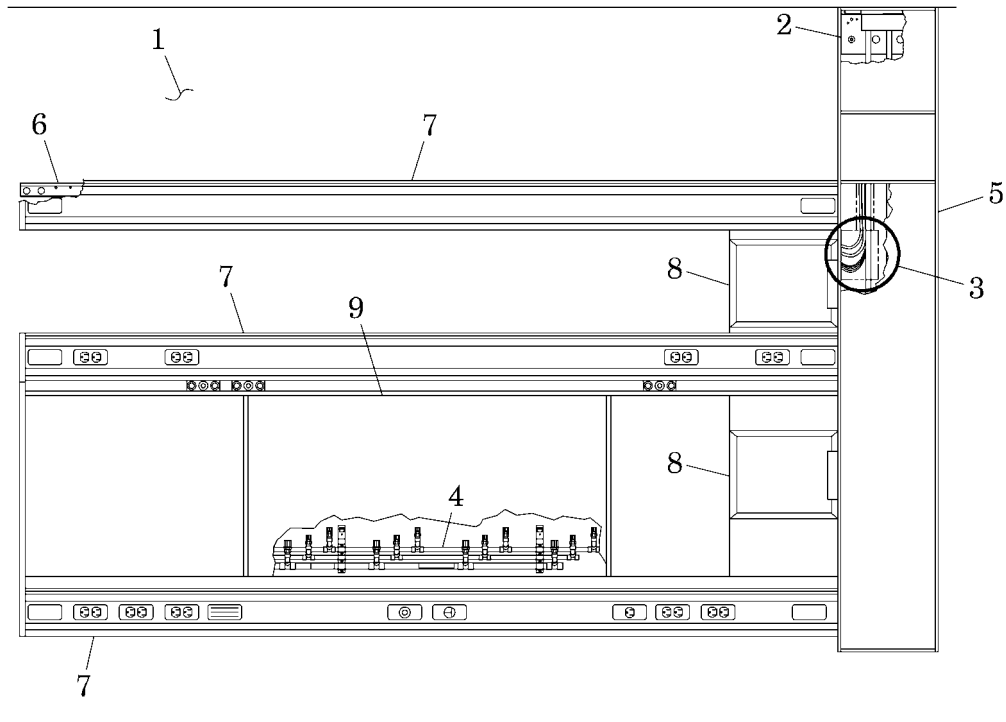

i563_002

Fastener Identification

For proper fastener identification, the fasteners in the following installation instructions are referred to by callout letter (see figure 3 on page 4).

Determine the Wall/Construction Type



WARNING:

The installation method differs for each wall and construction type. Failure to determine the wall and construction type could result in personal injury or equipment damage.

1. Determine the wall type and construction type before proceeding.
 - a. For **seismic** walls, contact Hill-Rom Technical Support at (800) 445-3720.
 - b. For **non-seismic** walls, proceed with the installation according to these instructions.
 - c. Install wall backing plates according to the Office of Statewide Health, Planning, and Development (OSHPD) approved drawings and the as-built drawings, and proceed according to these instructions.

Figure 3. Fasteners

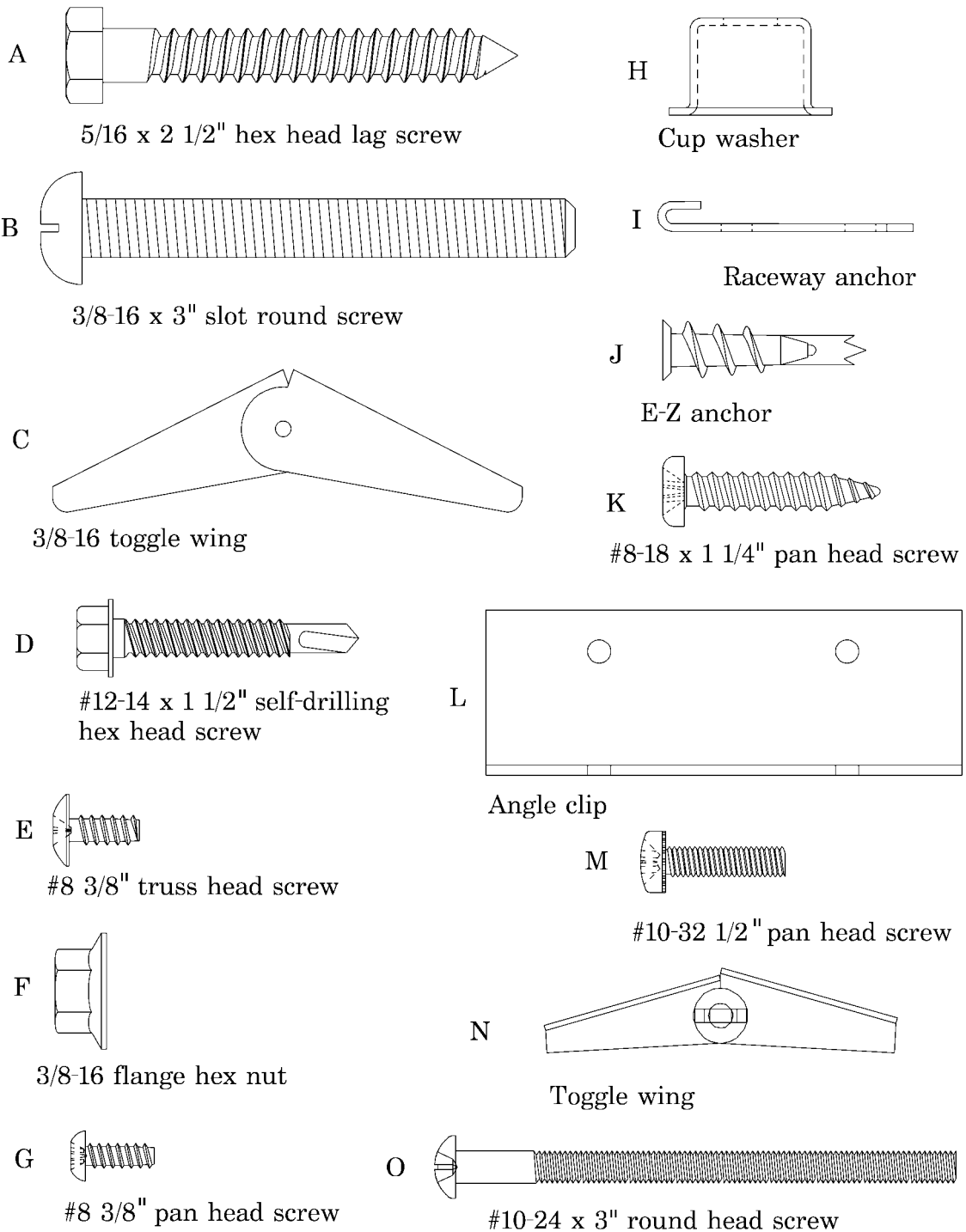

i563_003

Install the Vertical Chase Hanger

1. Refer to as-built drawings for the required dimensions.
2. Establish the location of the vertical chase (right, left, or center), as required according to the as-built drawings (see figure 4 on page 5).

Figure 4. Chase Hanger Installation

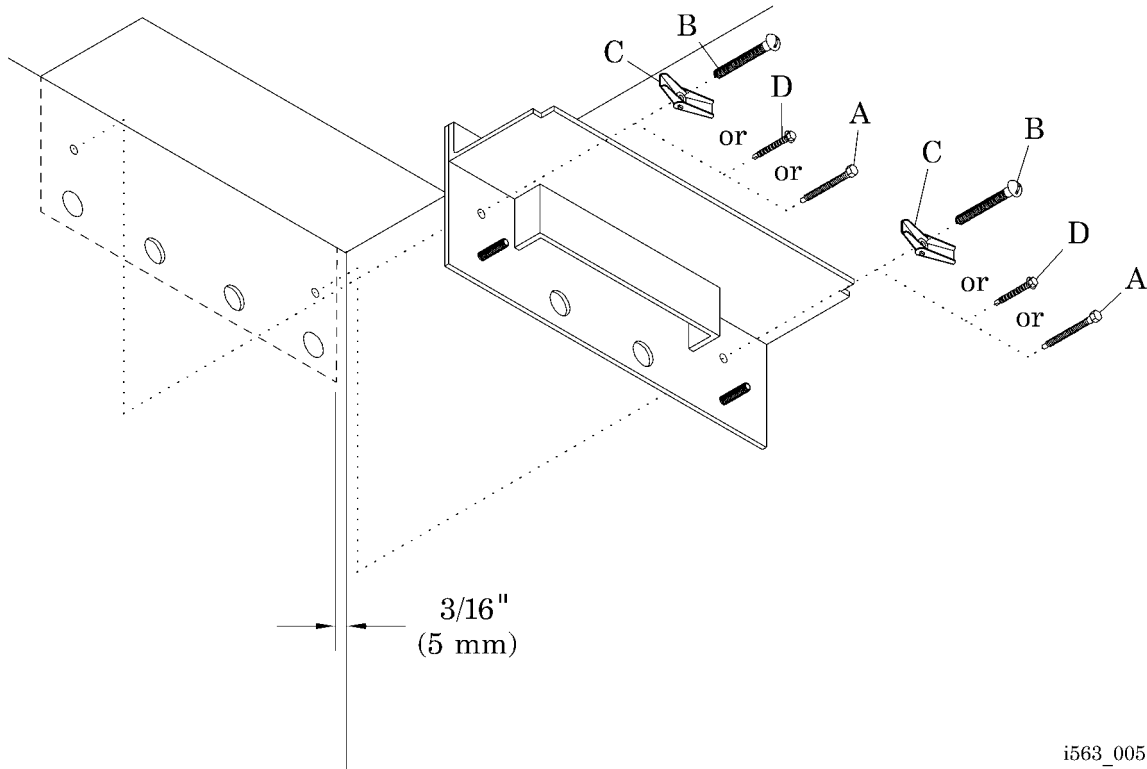

i563_005

3. If the ceiling is not already installed, establish the ceiling line.
4. Allowing a 3/16" (5 mm) clearance from the wall, temporarily locate the chase hanger, with the top edge at the ceiling line. If the vertical chase is centrally located in the room, locate the hanger on the centerline.
5. While holding the chase hanger, mark the locations for either the lag screws (A), screws (B) and toggle wings (C), or self-drilling screws (D) (seismic).
6. Dimple the drywall at the locations shown to allow for stud welds on the back of the hanger.



SHOCK HAZARD:

Ensure that no electrical power is supplied to the facility wiring. Personal injury or equipment damage could occur.

7. Disconnect and tag all electrical power from any wiring behind the wall(s) where the vertical chase hanger will be mounted.
8. Use one of the following steps, depending on the fastening method selected:
 - If lag screws (A) are used, drill 3/16" holes at the locations marked.
 - If screws (B) and toggle wings (C) are used, drill 1" diameter holes at the locations marked.
 - If self-drilling screws (D) are used, locate them according to the seismic engineering requirements.
9. Attach the vertical chase hanger.

Make the Electrical and Gas Services Drops

1. Remove the appropriate knock-outs according to the as-built drawings for the electrical and gas service drops (see figure 5 on page 6). Avoid bending the knock-out plate up toward the ceiling.

Figure 5. Chase Hanger Knockouts (raceway left)

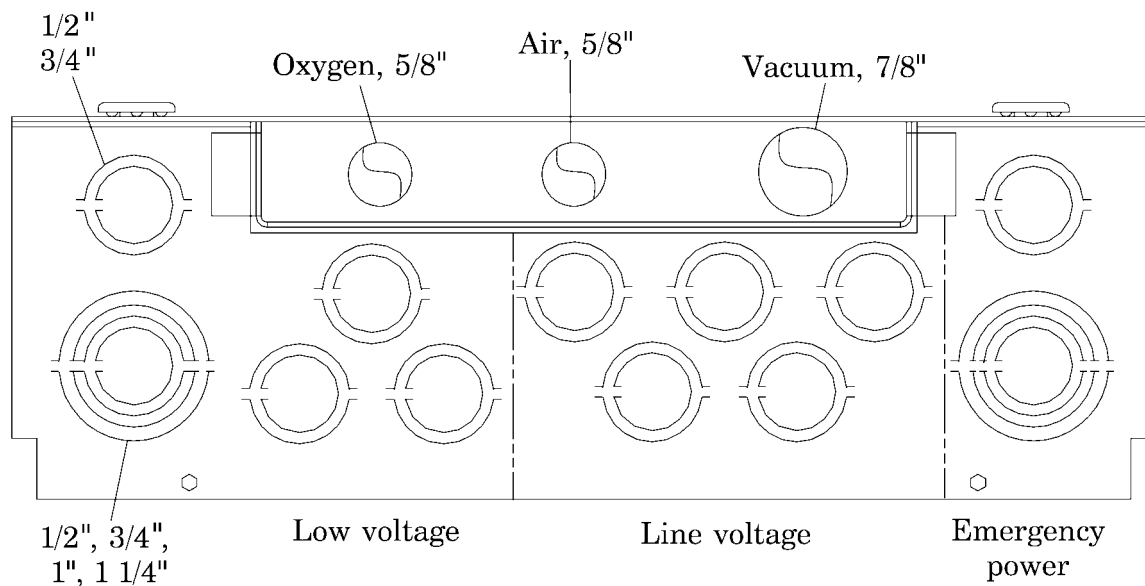

i563_006

NOTE:

Designated areas for line voltage and emergency power may be reversed if the volume of emergency power wiring exceeds line voltage wiring. Confirm locations from the as-built drawings.

2. Pull wiring for line voltage standard and emergency power circuits, leaving 18" of free length below the knock-out plate.



WARNING:

Ensure that the medical gas lines are in the proper orientation for connection to the gas manifold. If gasses are cross-connected, personal injury or death can occur.



CAUTION:

Assure that the roughed-in medical gas lines are properly positioned to drop within the top opening of the chase hanger. Do not force or bend the gas pipes to fit. Equipment damage could occur.

3. Following figure 6 on page 8, install the medical gas service piping, in the order shown, through the openings in the chase hanger. The drops must extend no closer than 20" (51 cm) from the finished floor, in accordance with National Fire Protection Association (NFPA) 99, and any applicable local codes.

Install the Medical Gas Manifold

If medical gasses are installed on both sides of the vertical chase, install a tee fitting on the end of each drop. The dimensions must not exceed those shown in figure 6 on page 8 and figure 7 on page 9. The gas manifold assembly is located behind the the 48" wide panel(s), normally centered at each bed location.

NOTE:

Each patient room bed position requires a manifold assembly. Connecting fittings and piping required between manifold assemblies is supplied by the installer.

1. Refer to the as-built drawings for the manifold centerline. Mark a vertical line on the wall at this location.
2. Position the manifold assembly on the wall, with the centerline label on the manifold centered on the vertical line drawn on the wall. The bottom of the lowest tube must be no closer than 20" (51 cm) from the finished floor, and the top of the highest tube no higher than 25" (64 cm) from the floor.
3. Mark the locations of the manifold hanger bracket holes.

Figure 6. Medical Gas Drops

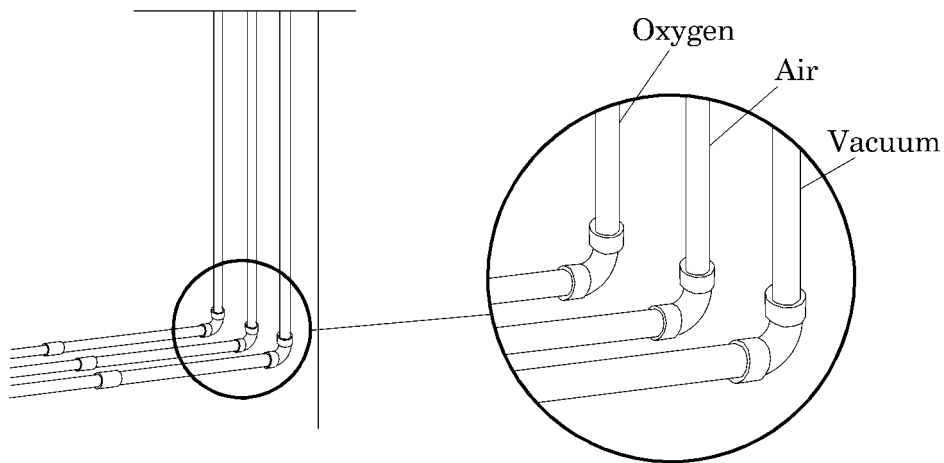

View of connection
for a single manifold
to a service drop

or

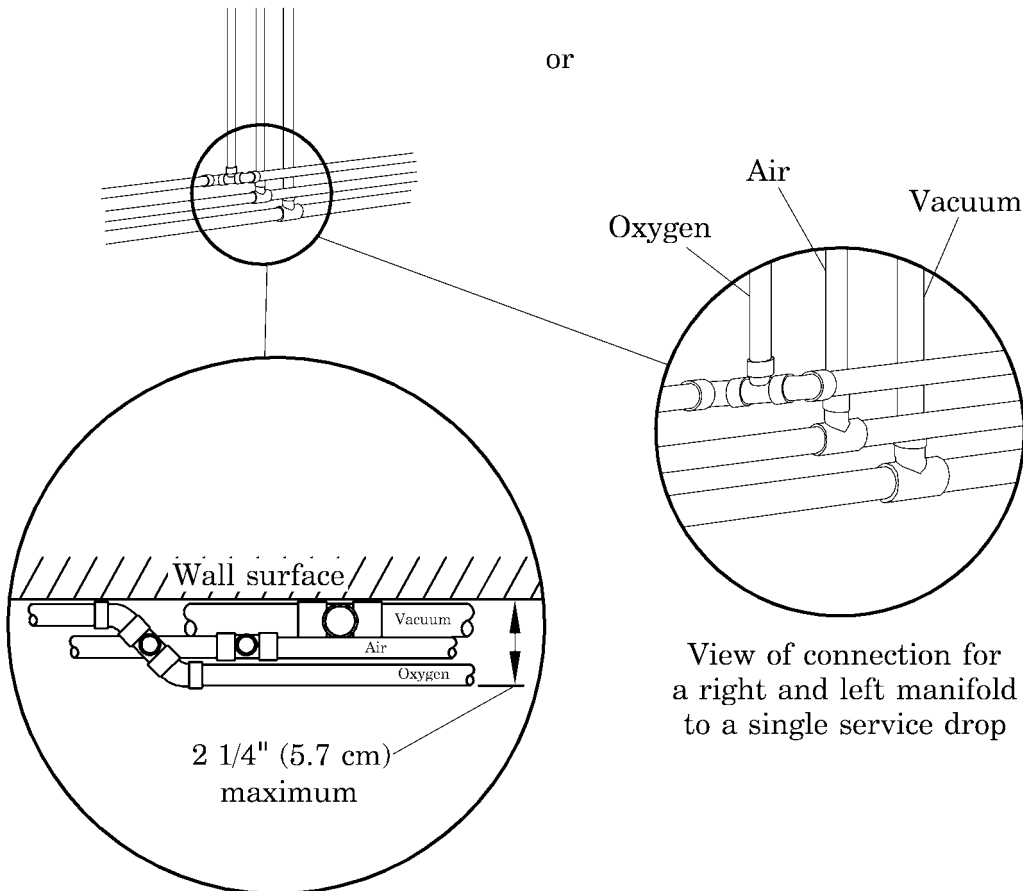

View of connection
for a right and left manifold
to a single service drop

i563_007

Figure 7. Medical Gas Manifold Installation

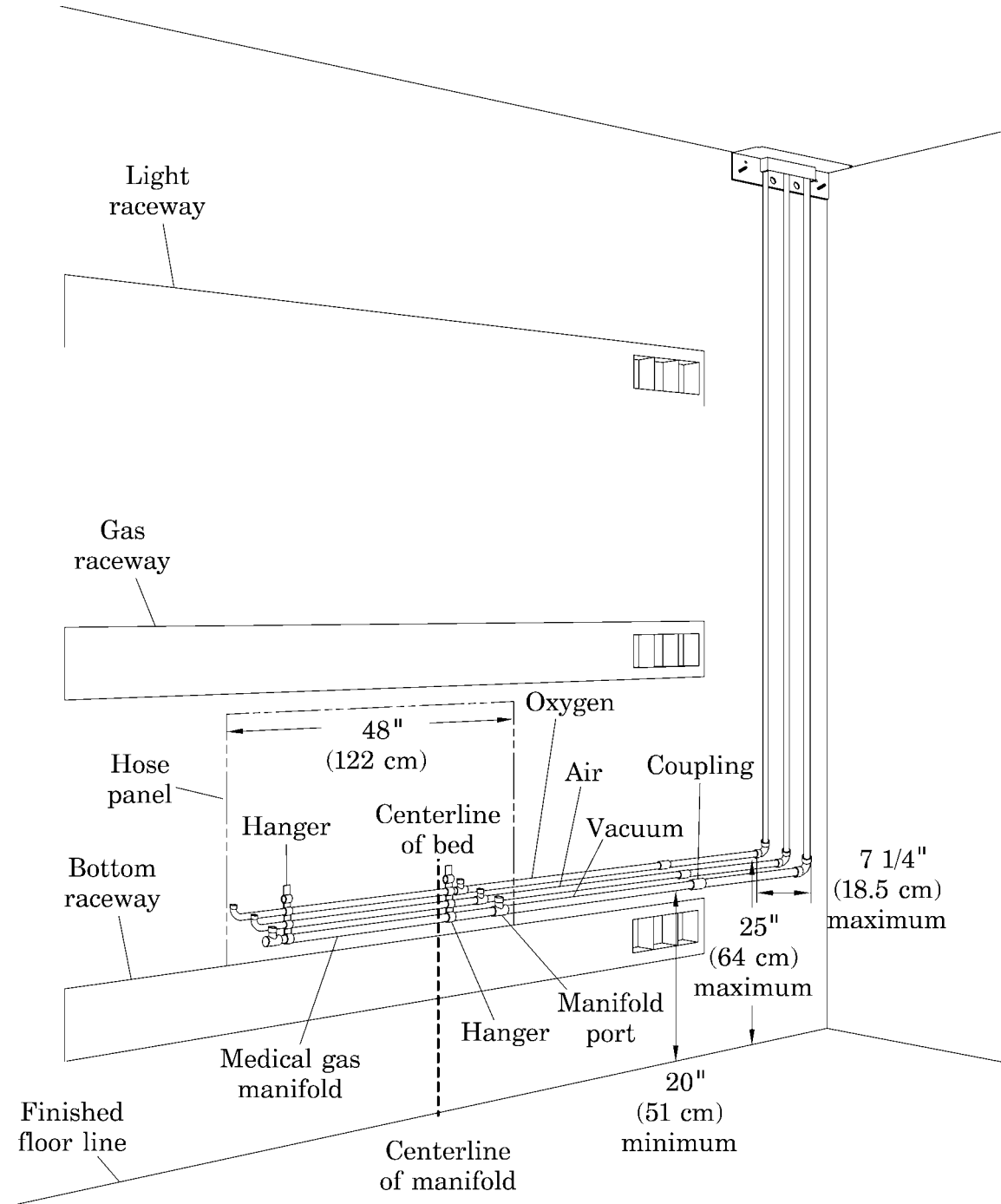

i563_008



SHOCK HAZARD:

Ensure that no electrical power is supplied to the facility wiring. Personal injury or equipment damage could occur.



WARNING:

The installation method differs for each wall and construction type. Failure to determine the wall and construction type could result in the collapse of the Horizon® Headwall System. Personal injury or equipment damage could occur.

4. Disconnect and tag all electrical power from any wiring behind the wall(s) where the medical gas manifold will be mounted.
5. Secure the manifold in one of these ways:
 - If installing to meet seismic area requirements, secure the manifold to the backing plate with self-drilling screws (D).
 - Otherwise, secure the manifold to the wall with fasteners N and O.



CAUTION:

If the medical gas drops are not properly located, it will be necessary for a contractor to relocate them. Otherwise, equipment damage could occur.

6. Make certain the connections to the medical gas supply are located in the center of the chase, with the oxygen supply connection closest to the raceway.
7. Connect the copper tube fittings from the gas manifold assembly to the medical gas service drops according to National Fire Protection Association (NFPA) 56, “Non-flammable Medical Gas Systems.”

Install the Vertical Chase

Before installation, verify the vertical chase installation specifics against the as-built drawings for correct length and hand.

1. Remove the screws (E) securing the upper side trim from the raceway side of the vertical chase (see figure 8 on page 11).
2. Remove the trim, and slide out the panel covering the J-box area.
3. Position the vertical chase near the chase hanger and feed the electrical wiring through the J-box area.

Figure 8. Vertical Chase

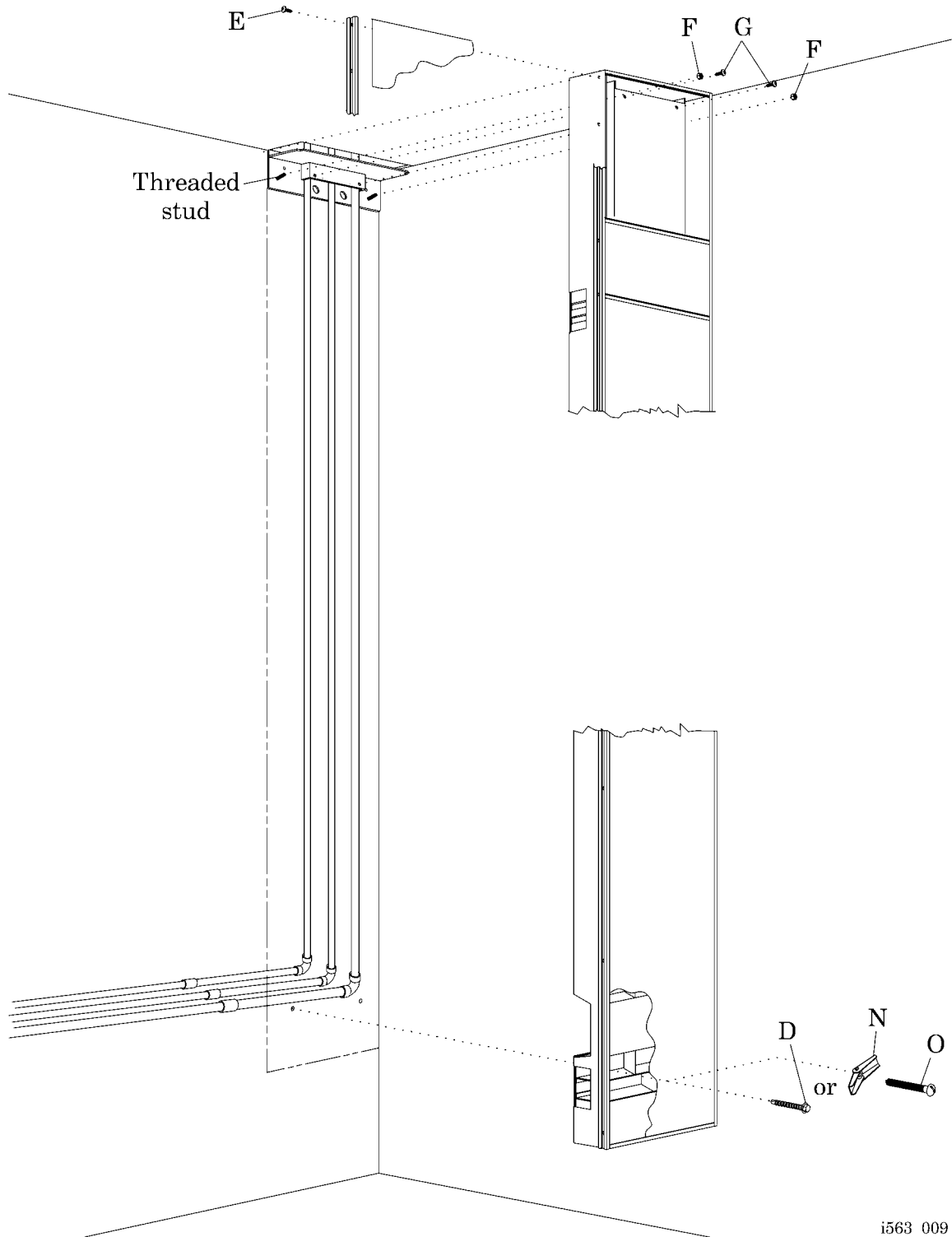

i563_009

4. Place the vertical chase onto the 3/8" threaded studs projecting from the chase hanger. The electrical knock-out plate of the hanger bracket must fit beneath the trim bar at the top of the vertical chase when the vertical chase is fully seated.
5. Install the 3/8 - 16 flange hex nuts (F) on the threaded studs.
6. Install two pan head screws (G) into the hanger plate.
7. Remove the lower side trim from the raceway side of the vertical chase, and slide out the lower panel.



SHOCK HAZARD:

Ensure that no electrical power is supplied to the facility wiring. Personal injury or equipment damage could occur.

8. Disconnect and tag all electrical power from any wiring behind the wall(s) where the vertical chase will be mounted.
9. Through the holes in the back on each side, drill holes in the wall for securing the lower section of vertical chase.
10. Secure the vertical chase in one of these ways:
 - If installing to meet seismic area requirements, secure the vertical chase to the backing plate with self-drilling screws (D).
 - Otherwise, secure the vertical chase to the wall with fasteners N and O.
11. Connect the electrical services from the J-box to the pre-installed wiring in the vertical chase.
12. For services that are not preinstalled (generally low voltage signalling and monitoring), feed the conductors and cabling from the J-box through 1¼" conduit into the lower portion of the vertical chase.
13. After raceways and (if required) breaker panels have been installed, replace the upper and lower panels and side trim pieces, and secure with screws (E).

Install the Raceway Hanger Brackets

NOTE:

The horizontal raceway sections are of varying lengths and may be abutted to span greater lengths. Your installation may not require all types. Refer to your as-built drawings for details.



WARNING:

Installation methods differ for each wall and construction type. Failure to determine the wall and construction type could result in the collapse of the Horizon® Headwall System. Personal injury or equipment damage could occur.

1. Locate the openings in the side of the vertical chase (see figure 9 on page 14).
2. Measure up 3/8" (9.5 mm) from the divider separating the upper and middle sections in each chase opening and place a mark on the wall.
3. Strike a level horizontal chalkline on the wall at least as long as the horizontal raceway.
4. Repeat for each horizontal raceway, maintaining proper spacing between chalklines for the full length.

NOTE:

For non-seismic installation, the alternate hole is used if an obstruction or wall stud is encountered.

5. Place a section of the raceway hanger bracket on the wall with the **bottom flush with the chalkline**:
 - For non-seismic installation, trace the pairs of 1" diameter hole to determine where to make the mounting holes.
 - For seismic installation, mark the pre-drilled holes for the self-drilling screws (D).
6. Repeat for the other sections of horizontal raceway.



SHOCK HAZARD:

Ensure that no electrical power is supplied to the facility wiring. Personal injury or equipment damage could occur.

7. Disconnect and tag all electrical power from any wiring behind the wall(s) where the horizontal raceway will be mounted.
8. For non-seismic installation, at each pair of holes, drill only one 1" hole in the drywall, assuming an obstruction or wall stud is not encountered.

Figure 9. Raceway Hanger Bracket Installation

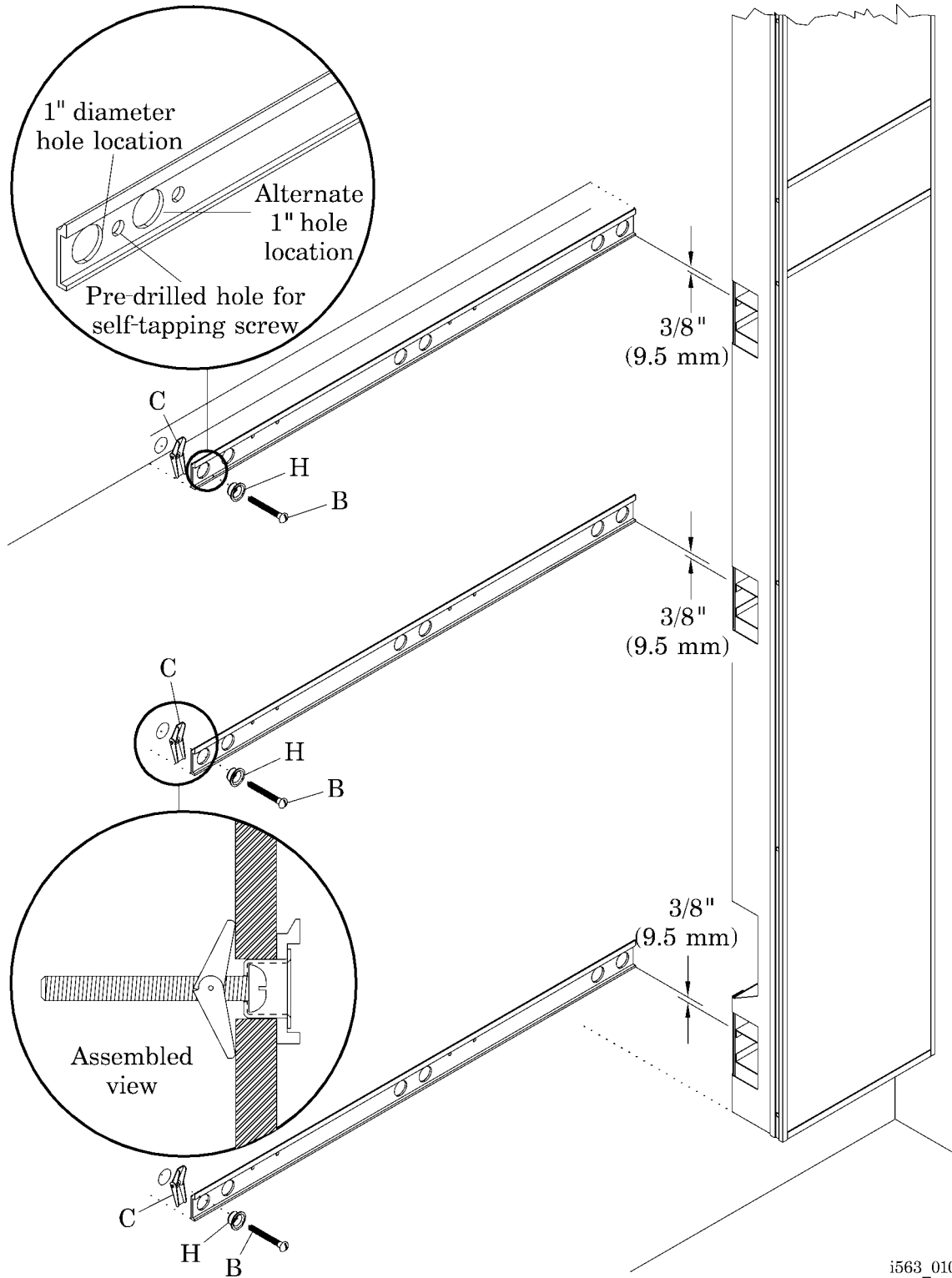

NOTE:

When installing multiple raceway hanger brackets, ensure that any additional raceway hanger brackets are level with the first raceway hanger bracket installed.

9. Secure the raceway hanger brackets in one of these ways:
 - If installing to meet seismic area requirements, secure the raceway hanger brackets to the backing plates with self-drilling screws (D), **or**:
 - Secure the raceway hanger brackets to the wall with fasteners B, C, and H.
10. Verify that the raceway hanger brackets are level and that the proper spacing between them is maintained.
11. If the wall has waviness exceeding 1/16" (1.6 mm) per foot, loosen the fasteners at the low spot(s), shim behind the raceway hanger bracket, and then tighten the fasteners.

Install the Horizontal Raceways

1. Locate the horizontal raceway section that will be next to the vertical chase.
2. Place raceway anchors (I) in the lower rear groove, spacing evenly (see figure 10 on page 15). Use three anchors for 9-foot sections, or two for shorter sections.

Figure 10. Horizontal Raceway Installation

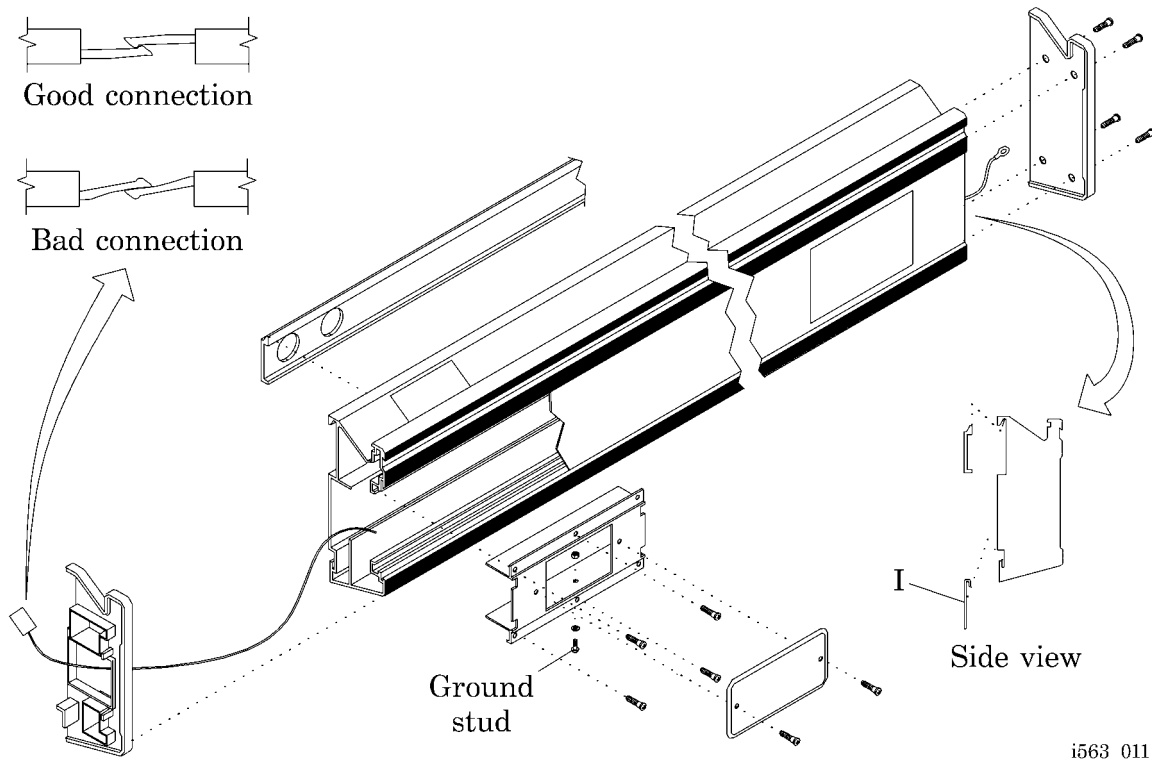

3. Fit the horizontal raceway section over the hanger, leaving about a 3" (8 cm) gap between the horizontal raceway and vertical chase.

NOTE:

The top barriered opening is for low voltage. The middle opening is for line voltage. The bottom opening is for emergency power.

4. Feed electrical connector pigtails and pullcords from the horizontal raceway through the appropriate barriered openings in the vertical chase.



CAUTION:

Make sure that the metal barriers in the vertical chase openings mate properly with the plastic sleeve on the end of the horizontal raceways. Otherwise, wiring could be pinched and damaged.

5. Slide the horizontal raceway toward the vertical chase until the plastic sleeve on the horizontal raceway seats against the chase.
6. Repeat **steps 2 through 5** for each horizontal raceway section.



SHOCK HAZARD:

Ensure that no electrical power is supplied to the facility wiring. Personal injury or equipment damage could occur.

7. Disconnect and tag all electrical power from any wiring behind the wall(s) where the breaker panel will be mounted.
8. Anchor the horizontal raceway sections by one of two methods:
 - a. Evenly space the retainers in the lower grooves and secure with the E-Z anchors (J) and mounting screws (K).
 - b. If exposed retainer clips are not desired:
 1. Remove the faceplate and device at a location at each end of the horizontal raceway sections.
 2. Taking care to protect any wiring, drill through the back of the horizontal raceway.
 3. Anchor at those locations, using items J and K for non-seismic or item D for seismic installation.
 4. Replace the devices and faceplates.

**CAUTION:**

After making electrical plug connections between the horizontal raceways and vertical chase unit, visually check for proper mating positions. Failure to make a good connection could likely result in heat buildup, smoke, and interruption of power.

9. In the vertical chase, make connections for line voltage and emergency power circuits. Visually check for correct plug connections (see figure 10 on page 15).
10. Connect the ground wires to the ground bar in the vertical chase.
11. Check continuity between the farthest receptacle ground of each horizontal raceway and the vertical chase ground bar.
12. Route all signalling circuit wires and cabling to the appropriate horizontal raceway, attach to pullcords, and pull into the appropriate backbox.
13. Once all wiring is complete and verified, install the vertical chase cover and trim. See “Install the Vertical Chase” on page 10.

Installing Additional Horizontal Raceway Sections

1. When more than one horizontal raceway section is required for length, locate the next section, and on the end toward the vertical chase, remove the blank faceplate, exposing the ground stud.
2. Fit the horizontal raceway section over the hanger, leaving about a 3" (7.6 cm) gap between the two raceway sections.
3. Make connections for the line voltage and emergency power circuits.
4. Feed the ground wire from the first horizontal raceway section (next to vertical chase) into the next section and connect it to the ground stud.
5. Tie the ends of the pull cords together.
6. Slide the horizontal raceway section toward the adjacent section until the plastic sleeve seats securely.
7. Anchor the horizontal raceway section according to step 8 on page 16.
8. Repeat the above steps for all raceway sections.

Install the Breaker Panel(s)

Refer to the as-built drawings for your particular installation. If breaker panels are not included, skip this section, and go to “Install the Hose Panels” on page 21.

For power distribution diagrams and theory of operation, refer to the *Horizon® Headwall System Service Manual*, man043ra.

Lower Breaker Panel

1. Remove the lower trim and front panel from the vertical chase (see figure 8 on page 11).
2. Open the door on the breaker panel and remove the deadfront and door.
3. Install the angle clip (L) with screws (G) on the breaker panel side opposite the vertical chase (see figure 11 on page 18).
4. Position the breaker panel Z-brackets into the slot projecting from the top of the bottom horizontal raceway, and slide the breaker panel until snug against the vertical chase.
5. Mark the hole locations on the wall for the top mounting bracket.

Figure 11. Lower Breaker Panel

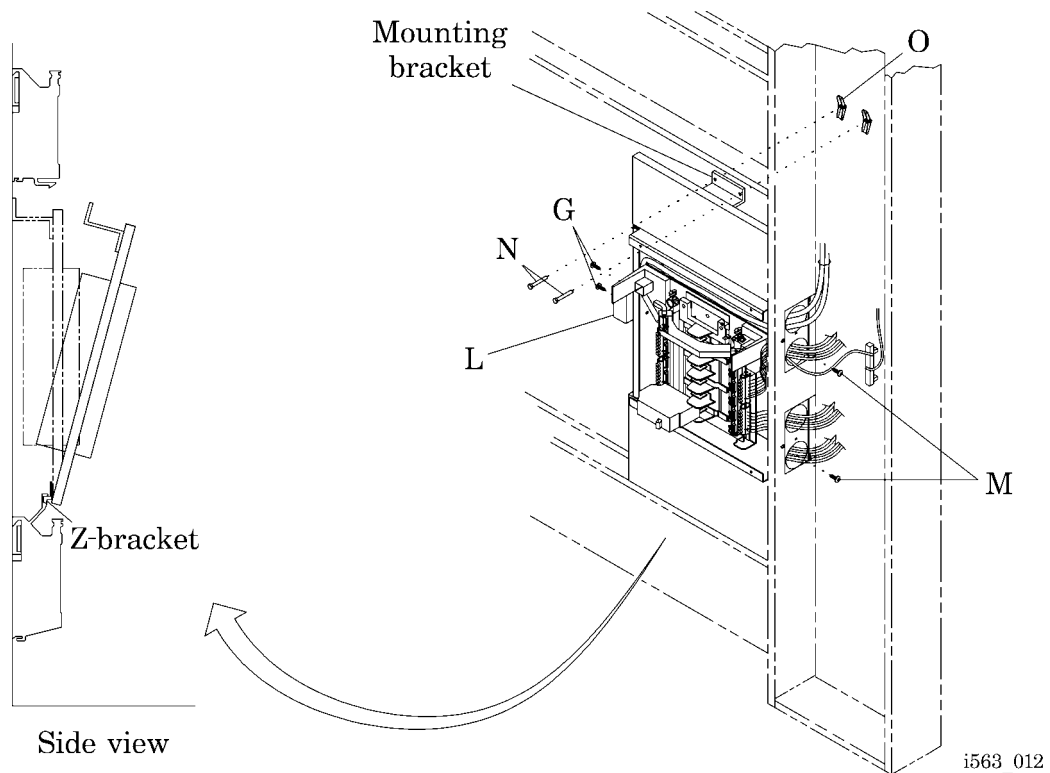



SHOCK HAZARD:

Ensure that no electrical power is supplied to the facility wiring. Personal injury or equipment damage could occur.

6. Disconnect and tag all electrical power from any wiring behind the wall(s) where the breaker panel will be mounted.
7. Remove the breaker panel, and drill holes in the wall in preparation for fasteners N and O.
8. Position the breaker panel on the horizontal raceway, and install two screws (M) from the inside of the vertical chase into the side of the breaker panel. Reposition or temporarily remove chase parts as necessary.
9. Secure the top mounting bracket to the wall with fasteners N and O.
10. Route the breaker panel raceway connectors and wiring through the openings into the vertical chase.
 - a. Route #10 AWG green ground wire to the ground bar.
 - b. Route #6 AWG main feed conductors to the line voltage junction box and the connector to the terminal block.
11. After all electrical connections are made and verified, replace the deadfront and breaker panel door, then install the lower front panel and trim.

Upper Breaker Panel

1. Remove the upper trim and front panel from the vertical chase (see figure 8 on page 11).
2. Open the door on the breaker panel, and remove the deadfront and door (see figure 12 on page 20).
3. Position the breaker panel in place, and slide it into the desired mounting position.
4. Mark one or more mounting positions on the wall through mounting hole(s) in the back wall of the breaker panel tub.



SHOCK HAZARD:

Ensure that no electrical power is supplied to the facility wiring. Personal injury or equipment damage could occur.

5. Disconnect and tag all electrical power from any wiring behind the wall(s) where the breaker panel will be mounted.

Figure 12. Upper Breaker Panel

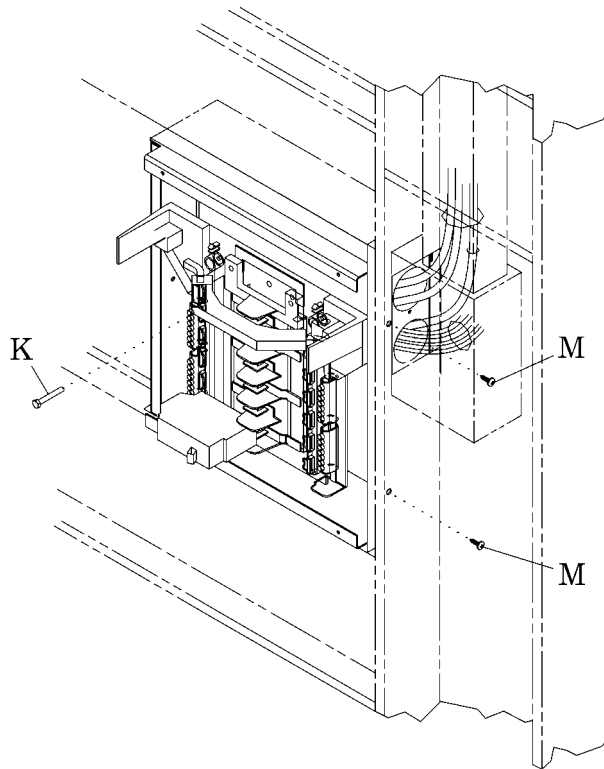

i563_013

6. Remove the breaker panel, drill holes for and install E-Z anchors (J).
7. Position the breaker panel in place.
8. Install two screws (M) from the inside of the vertical chase into the side of the breaker panel. Reposition or temporarily remove chase parts as necessary.
9. Secure the breaker panel to the back wall with screws (K)
10. Route the breaker panel raceway connectors and wiring through the openings into the vertical chase.
 - a. Route #10 AWG green ground wire to the ground bar.
 - b. Route #6 AWG main feed conductors to the emergency power junction box and the connector to the terminal block.
11. After all electrical connections are made and verified, replace the deadfront and breaker panel door, then install the vertical chase upper front panel and trim.

Install the Hose Panels

1. Refer to the as-built drawings for your particular installation.

NOTE:

Make certain that the hose panels are properly identified before installation. The center panel has sliding latches on the top edge only, and must be installed last.

2. Locate the hose panel designed to be next to the vertical chase.
3. Place the Z-bracket into the slot projecting from the top of the bottom horizontal raceway (see figure 13 on page 21).

Figure 13. Hose Panel

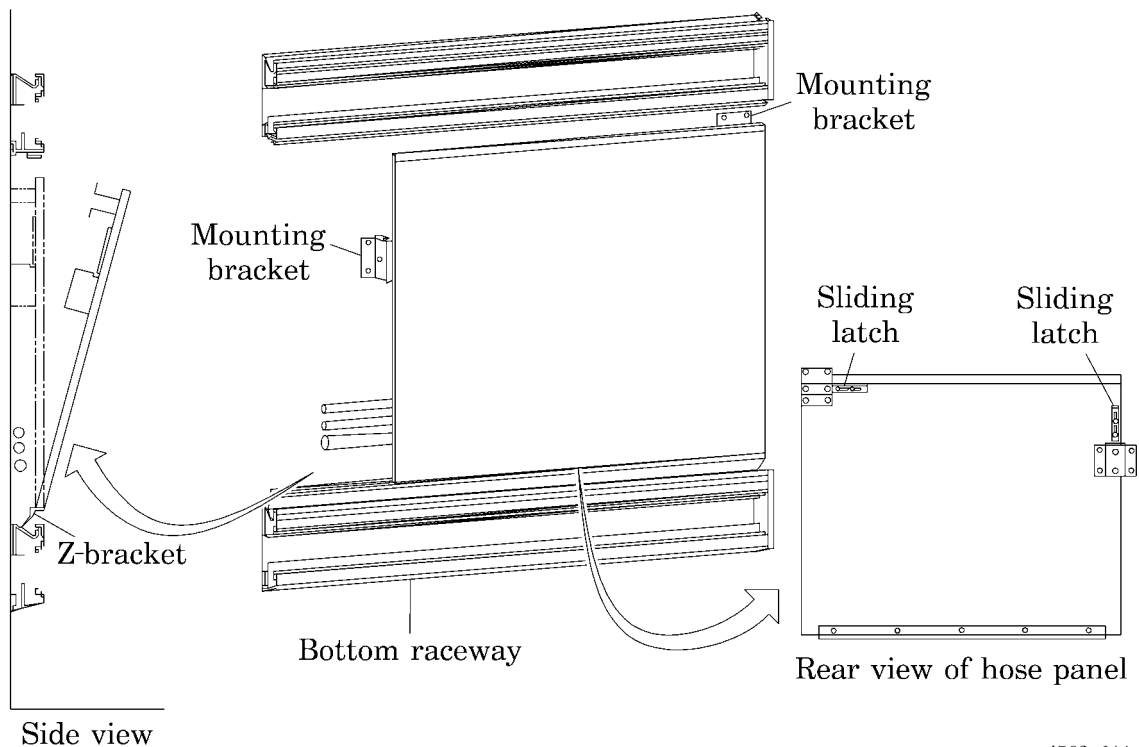

i563_014

4. Rotate the hose panel up to the full vertical position, and mark the outer hole positions for the panel mounting brackets.
5. Remove the hose panel, and detach the mounting brackets from the panel.
6. Position the removed mounting brackets over the previously marked hole positions, and mark the remaining holes.



SHOCK HAZARD:

Ensure that no electrical power is supplied to the facility wiring. Personal injury or equipment damage could occur.

7. Disconnect and tag all electrical power from any wiring behind the wall(s) on which the hose panels will be mounted.
8. Attach the panel brackets to the wall with fasteners N and O.
9. Remove the screws from the panel that held the panel brackets in place.
10. Replace the hose panel, and secure it by sliding the latches under the panel brackets.
11. Locate the manifold access panel. This panel has two sliding latches on the upper back side of the trim edge. Place this panel **temporarily** in position to act as a spacer for the outer panel. Leave 1/16" (1.6 mm) clearance between panels.
12. Repeat steps 3 through 11 for the outer panel.
13. Position the manifold access panel between the two outer panels by placing the Z-bracket into the top slot on the lower horizontal raceway, and rotating the panel up to the full vertical position.
14. Secure the center panel by sliding the two latches outward and under the edge of the adjacent panels.

Connect the Medical Gas Outlets

1. Refer to the as-built drawings for the number and type of medical gas outlets to be installed.
2. Remove the manifold access panel to expose the medical gas manifold assembly.

NOTE:

The manifold outlet assembly and hose connections are provided with DISS indexing to prevent cross-connection between gasses.



CAUTION:

Make sure hoses are not twisted or crimped behind the hose panels. Improper gas delivery or hose damage may result.



CAUTION:

Connect medical gas hoses to the manifold assembly **finger tight**. Overtightening may result in damage to the fitting.



WARNING:

Do not force a hose onto a connection that is not exactly mated. **Do not** change connectors to another type on outlets or hoses. Personal injury or death could result.

3. Connect the outlet and hose assembly to the gas manifold (see figure 14 on page 23).

Figure 14. Gas Outlets

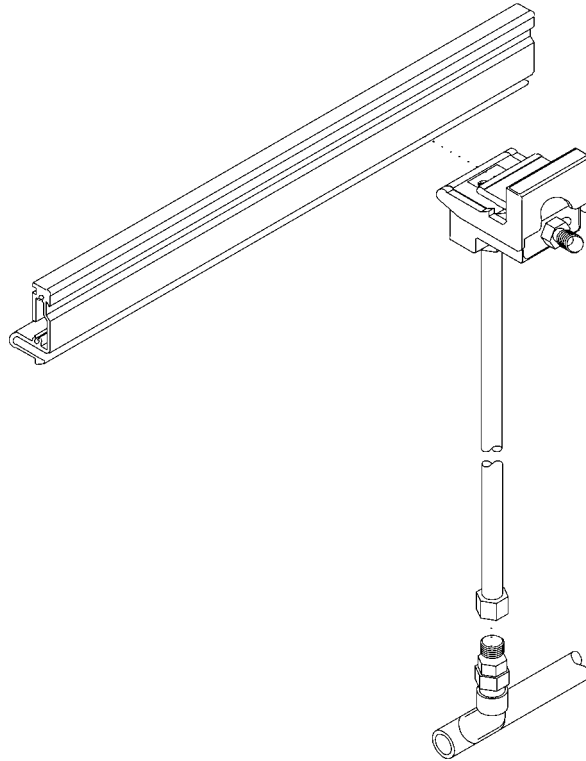

i563_015

4. Connect the gas outlet block into the horizontal raceway slot as shown.

NOTES:
